

Lucas DR3A Two-Speed Wiper-motors

The Lucas two-speed variant of the DR3A wiper-motor, as found on Triumph TR4A and other vehicles from the same era, seem to create problems when people try to wire them up.

Often this happens when someone tries to use one to upgrade from a single-speed variant. There are a number of things about these motors that are “counter-intuitive” and this leads people to guess wrongly in the absence of proper wiring instructions.

There will be useful information in here about using the single-speed types too and for the earlier DR2 type, found in TR2/3s and elsewhere, because these use more or less the same electrical parts even though the gear-wheels are different.

Rather than just give a set of step-by-step instructions, I want to explain how these motors achieve two-speed running. Hopefully this will put people on the right course to fit these as an upgrade in various suitable vehicles.

The single-speed Lucas motors from this period run a bit slow by modern standards. I'll be explaining how to speed them up a bit, so that if used with “intermittent-wipe”, performance is more like a modern unit.

There are two separate electrical circuits in these motors, the Field-winding and the Armature-winding, and the relationship between the current that goes through each of these determines the running speed.

The Field-winding is a large flat coil that is clamped to the outer case and its job is to magnetise the the outer case and the semi-circular “pole-piece”.

The Armature-winding is a round cage of wires, with the rotating drive-shaft in the centre. Current goes into the Armature-winding through the carbon-brushes.

I've got one of these from an E-type, that has all the wires from the Field and Armature-windings, brought out separately though the case. There are actually six wires in all! More on this variant later.

But the TR4A motors join some wires together inside and only three come out through the case. The diagram below shows how this is done. It also shows how the “self-parker” is wired in.

A standard single-speed DR3 motor does not bring the wires through the case, like a two-speed variant. It has two “spade” terminals that take push-on connectors. These are marked 1 and 2 in the alloy-casting, on the end of the motor.

There is a separate spade-terminal, marked E, which is for connecting the case of the motor, to the vehicle body. The motor will run perfectly even if you don't connect its case to the car-body. But it won't “self-park”.

The self-parker is a rotating contact that touches the case of the motor but only during about 3/4 of the wiper sweep. There is a “gap” where it makes no contact at all. If you connect the motor-case to the car-body, you can use this as a switch that keeps the motor running, until the contact reaches the gap that is and then it “parks”.

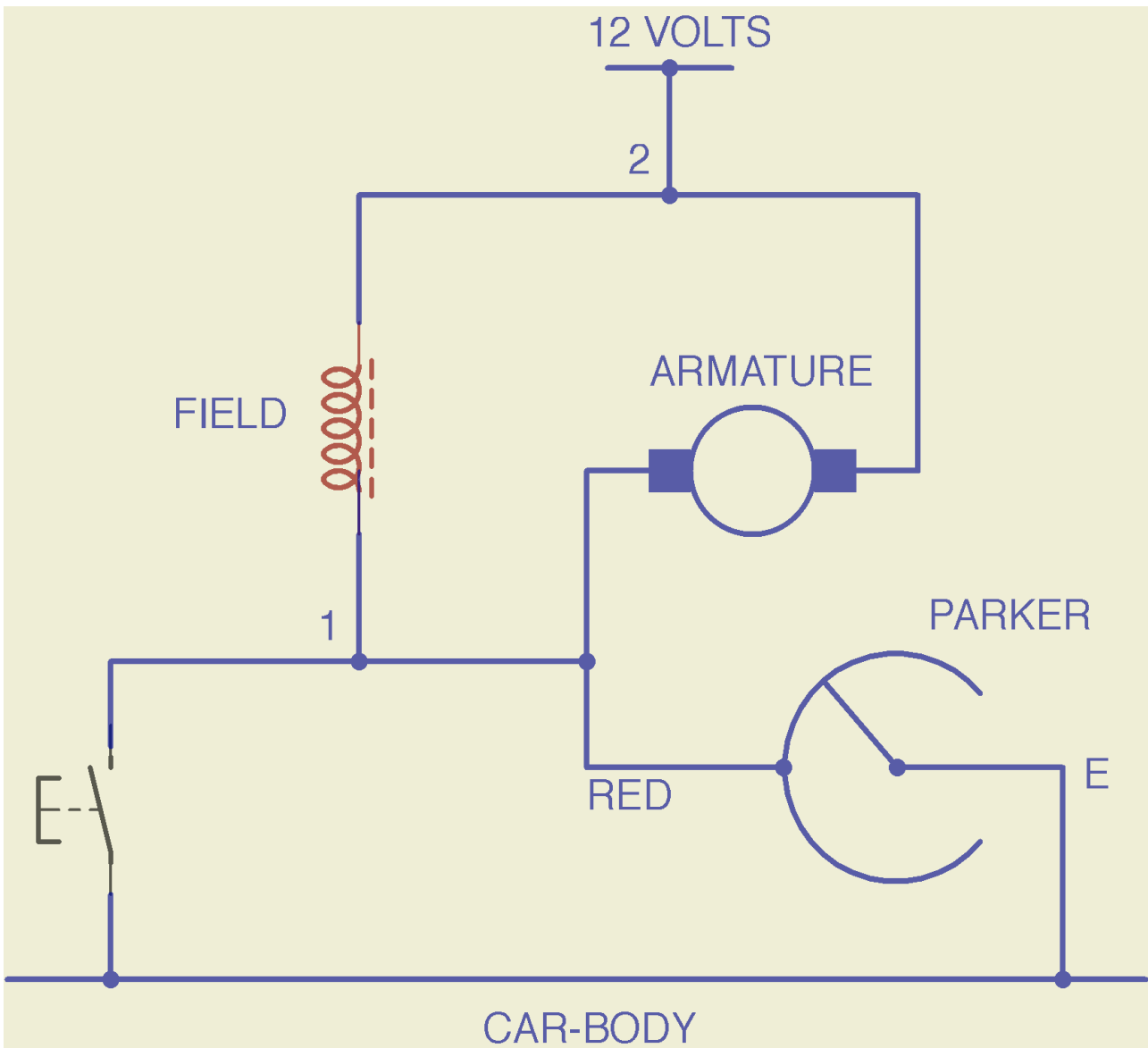

Check-out the following features on the diagram:

1. The 12V supply from the battery is at the top
2. it's connected to spade terminal number 2 and feeds the Armature-winding, through one carbon-brush and it also feeds the outer-end of the Field-winding.
3. the inner-end of the Field-winding is connected to the other carbon-brush. A connection from here comes out on spade-terminal number 1.
4. the wiper-switch is connected to spade-terminal number 1 and completes a contact to the car-body in order to start the motor.
5. the red wire that is so obvious on the round "cap", is connected to the car-body by the rotating contact, IF the motor-case is "earthed" by a wire on the E terminal AND the wipers are NOT in the "parking-position".

There isn't room to get three spades out of the case, so the two-speed motors squeezed the wires through the joint in the case and dispensed with the spades.

Part of the problem with converting to a two-speed motor is that you have to change from “spades” to “bullets” and this creates confusion. Especially as you have three wires on the motor and three wires on the car.

It just looks as if they should join somehow. But they don't join directly and nothing is obvious, because you need four wires from the car for a two-speed motor.

I've seen really complicated ways to get these motors to work. All have been created to overcome a problem that does not exist. They result from not understanding that the self-parker is a switch that makes a connection to the car body. A switch in the “earth-wire”.

This means that ALL the switching of the speeds has to be done with switches that make contact to car-body, switching in the “earth-wires” is the trick.

The other side of this is that there will be a direct connection from the motor to the side of the battery that is NOT connected to the body. Because this connection isn't switched there SHOULD BE A FUSE somewhere. One contact on the motor is “live” all the time. Or at least all the time that the ignition-switch is on.

Notice I have avoided using the word “positive” and “negative” because originally most of these were vehicles were wired with the positive-side of the battery connected to the car body, so called “positive-earth”, but many may have been altered to the modern “negative-earth” method. This change-over has no effect whatever on the way the wiper-motor should be wired.

The motors rotate the same way round no matter which side is connected to positive and which side to negative. This is because both the Field-winding and Armature-winding will get changed around and what is important is the relationship between the two circuits.

Note that the wipers will behave the same no matter which way the motor runs. But there is a “thrust screw” for one end of the armature shaft. The motor runs in the direction in which the armature “screws” itself towards the thrust-screw.

Now, you better choose carefully which motor contact you connect to the live side of the battery! Because if you choose the wrong one then the self-parker will make a contact from one side of the battery to the other. This WILL blow the fuse IF there is one! Otherwise the self-parker will burn out. The diagram above will make this clearer if you are puzzled.

Lucas chose to mark the “live” motor contact, on the single-speed units, with a figure 2 in the alloy casting. This is rather unexpected, I feel, and encourages people to wire the “power” to the wrong contact, marked with a figure 1. Yet another cause of confusion!

Now we have covered the basic switching and wiring for these motors and we come to the two-speed stuff.

If you have an electrical test-meter, that can measure low values of resistance, you can check out some of this for yourself.

The resistance of the Armature-winding is much lower than the field winding. I measure about 1 Ohm across the carbon-brushes. The field-winding of a single-speed motor, on its own, measures about 8.5 Ohms.

Both the Field and Armature-windings are connected to 12V so that Ohms law suggests that the current in the Field-wind will be 1.4A and 12A in the armature.

This is what happens at start-up OR if the wipers get jammed or are frozen to the screen. But the armature will BURN-OUT if the 12A continues for more than a few seconds.

Motors found in more “upmarket saloons” often have a thermal-switch to protect the motor. Triumph motors usually don't, after all the target market was California and drivers were not expected to use the wipers if they were frozen up!

As the motor runs up, the interaction of the field and the rotation generates a voltage and this causes the Armature current to fall back to its steady-running value which is about 2A. It is this interaction that allows us to vary the running speed.

If we reduce the strength of the magnetic-field, created by the Field-winding, then the Armature needs to turn faster to generate the same voltage. This means that to run faster, we want a SMALLER current in the Field-winding.

This is again counter-intuitive and anyone poking around inside the motor and finding the resistance-wire, that Lucas fitted to reduce the field-current, will probably assume that they need to wire the resistance in circuit when they want SLOW speed. This is not the case.

In fact Lucas put ten turns of Nickel-iron wire with a resistance of about 10 Ohms in the two-speed motors. This more or less halves the field current.

A simple view suggest that this will double the running speed. But it doesn't. You will see later that I have measured the speeds and this “field-weakening” only generates about a 50% increase in speed.

This is because of the phenomenon known as “magnetic saturation”. This means that there is a limit to the magnetic field you will get no matter how much current you use. Its a property of the Iron used to make the case and pole-piece.

These motors have been designed so that there is more than enough current to get the Iron saturated. This helps to get consistent performance in spite of manufacturing tolerances.

So reducing the Field-current a little does not reduce the speed. You need to halve it to get much effect. Even then you only get a 50% increase.

For convenience they wound the resistance-wire over the Field-winding. But there are not enough turns, compared with the main winding which has hundreds of turns ,to get any magnetic effect from this. Its just the resistance that's important. They could just as well have used a power-type resistor, but this would have cost more.

I am now adding power-resistors, to get faster running from the single-speed motors. These resistors are better at handling the heat generated and don't burn-out as easily as the bit of wire that Lucas used. More about this later.

So now we know we need:

1. a supply of 12V that comes on all the time that the “ignition” is on
2. a connection from the motor-case to the car body so that the self-parker will work
3. a three-position switch, making connections to the car-body
4. the switch must ensure that the field current is reduced, by the resistance-wire, in the FAST position but not in the SLOW position.

Again there is a trap for the unwary here. Not just any three-position switch will do!
To see why you must study the diagram below.

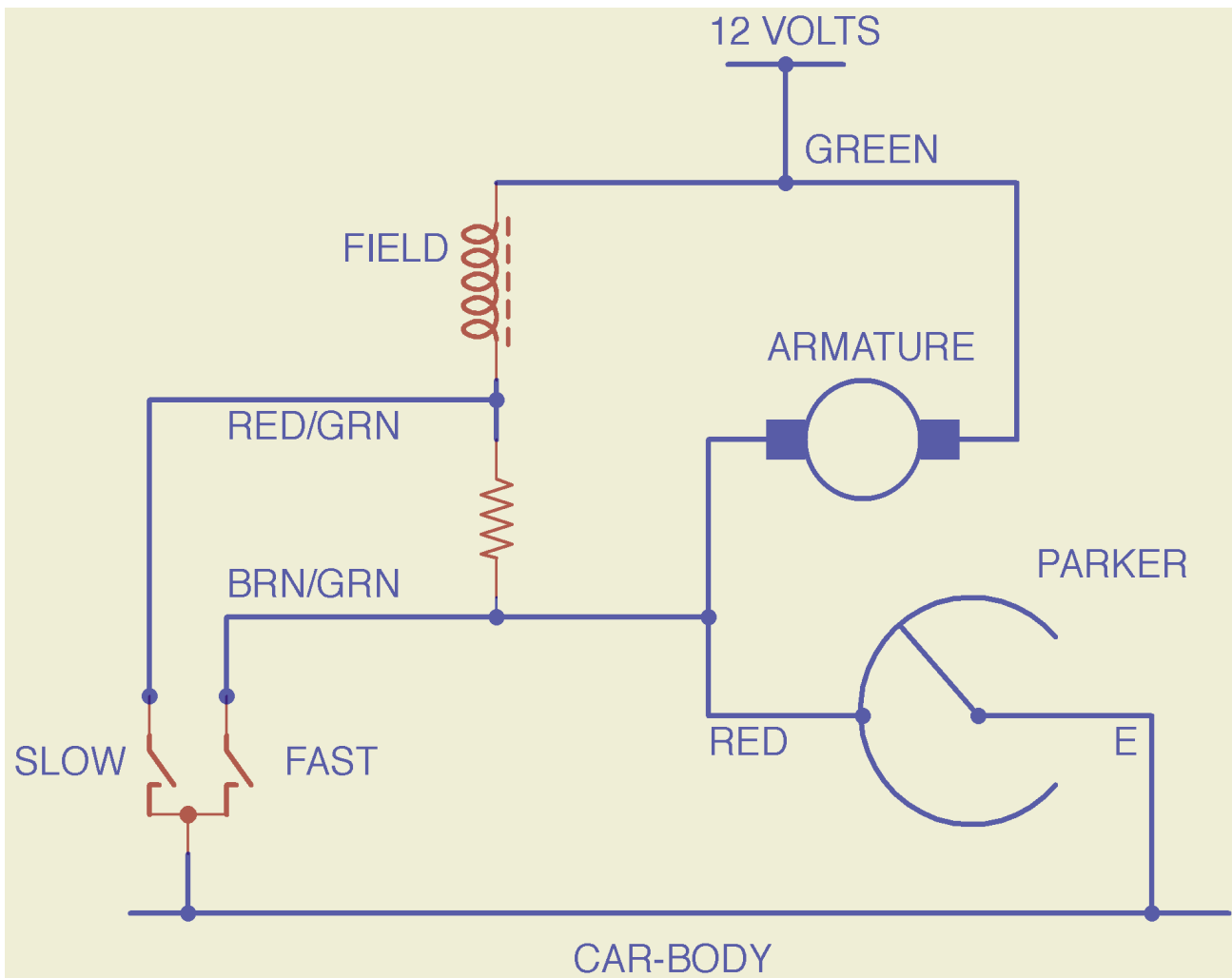

Check-out the following features on the diagram:

1. The 12V supply, from the battery uses a GREEN wire and feeds the Armature-winding through one carbon-brush and it also feeds the outer-end of the Field-winding
2. on a two speed-motor the Field coil has the same winding as a single-speed motor AND an "over-wind" of ten turns of resistance wire
3. one end of the resistance wire is connected to the other carbon-brush and comes out of the Motor-case on a BROWN/GREEN wire. I call this the FAST wire.
4. the joint between the resistance-wire and the inner-end of the ordinary copper-wire winding, comes out of the Motor-case using a RED/GREEN wire. I call this the SLOW wire.
5. the self-parker is wired and works just the same as the single-speed motor
6. as is often the case with these motors, the way the switches work isn't very obvious and needs the more detailed explanation below.

FAST RUN

This is easy to understand.

The Slow-switch is open and the Fast-switch works like the switch does on a single-speed motor.

The difference is that the resistance-wire is reducing the current in the Field-winding to about half the value of a single-speed motor and this causes the speed to increase.

Notice that the self-parker will operate in the same way as the fast-switch. So the motor will park at high-speed!

SLOW RUN

This is not so easy to understand.

Suppose we open the Fast-switch and close the Slow-switch. This is the obvious thing to do but its **WRONG**.

The current in the Field-winding would increase to the value used on the single-speed motors if we did this. But we would be feeding the Armature-winding through the resistance wire.

Two things will now go wrong. The motor won't get the 12A current needed to start.

But worse than this, the resistance-wire will, more or less, receive the whole 12V. This is because the Armature-winding only has a resistance of 1 Ohm and the motor won't run up.

In Fast-run mode the resistance-wire shared the 12V with the Field-winding. It got about 6V. Trust me, at 12V it will get **FOUR** times as hot as at 6V. You can figure what will happen.

The answer should be obvious by now. The Fast-switch **MUST** also be closed during the Slow-run mode.

Because both switches are closed there will be **NO CURRENT** in the resistance wire and the two-speed motor will run exactly like single-speed motor.

So now you know that you must find a three-position switch that does this job **AND** you have to identify which contacts work this way.

Unfortunately, the usual switch that Triumph used for this job actually has SIX contacts. Some of these are connected to each other all the time. The others jump about, joining to each other in a confusing way, as the switch is pulled.

So you need a test-meter or something to find which contacts work as required.

I checked out one of my spare 3-way Triumph switches, I've no idea if they are all the same as this. The contacts are numbered 1 to 8, except that contacts 3 and 6 were not fitted.

It works like this:

| position | from contact | to contact | and contact |
|---------------|--------------|------------|-------------|
| IN | 7 | ----- | 5 |
| MIDDLE | 7 | ----- | 5-----4 |
| OUT | 7 | ----- | 4-----8 |

So if you connected:

- 7 to the car-body (BLACK on a TR4A)
- 4 to the FAST-wire, (BROWN/GREEN on a TR4A)
- 8 to the SLOW-wire, (RED/GREEN on a TR4A)

then you would correctly get both speeds.

Contacts 1 and 7 are always joined so you could use 1 instead of 7 this is it suits you .

I have measured some details of the behaviour of these motors, as a means of checking their correct operation. The following data may be useful to others doing the same.

Speed RPM

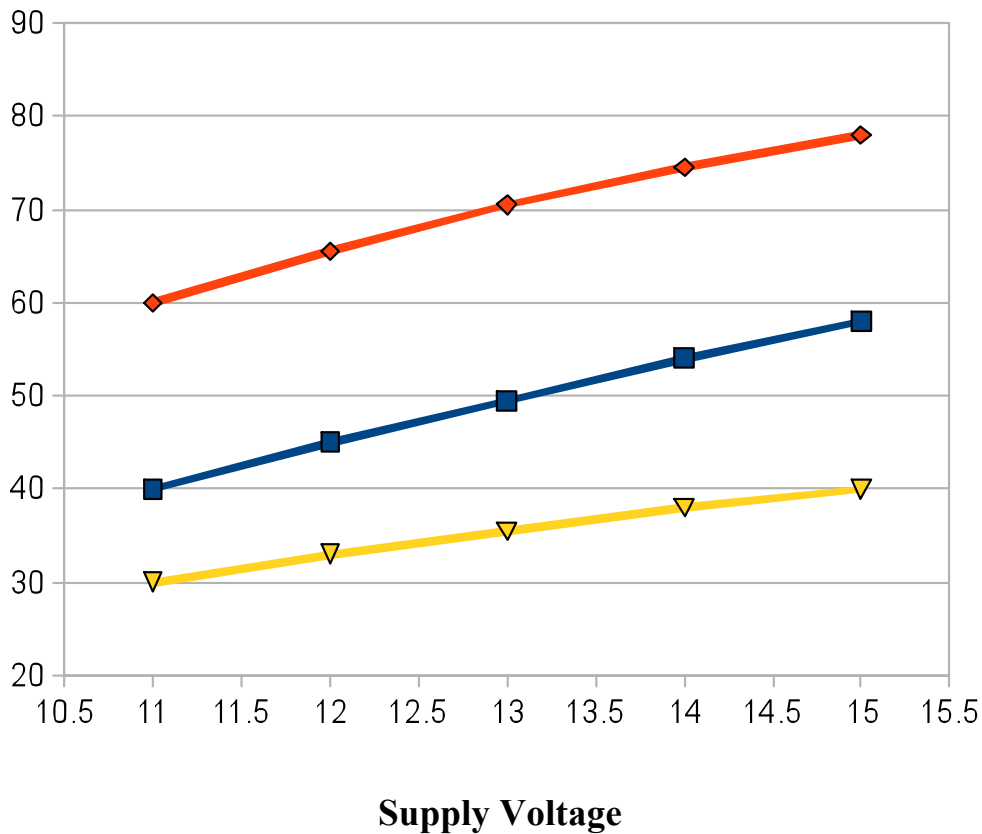

The line in **RED** is a two-speed motor running **FAST**
The line in **BLUE** is a two-speed motor running **SLOW**

The line in **YELLOW** is a comparative pedestrian early **DR2**

Note that these motors were “running-light” without a “rack” connecting to any actual wipers. They will run a bit slower when actually in service.

It should be easy to get the DR2 to run like a single speed DR3 with a bit of “field-weakening”.

