

## SECTION N

### THE ELECTRICAL EQUIPMENT

General description.

- Section No. N.1 Battery maintenance.
- Section No. N.2 Dynamo.
- Section No. N.3 Removing and replacing the dynamo.
- Section No. N.4 Dismantling the dynamo.
- Section No. N.5 Servicing the dynamo.
- Section No. N.6 Starter.
- Section No. N.7 Removing and replacing the starter.
- Section No. N.8 Servicing the starter.
- Section No. N.9 Control box.
- Section No. N.10 Fuses.
- Section No. N.11 Electric horn.
- Section No. N.12 Flashing direction indicators.
- Section No. N.13 Windshield wiper.
- Sections Nos. N.14 to N.23 Lamps.
- Section No. N.24 Replacement bulbs.
- Section No. N.25 Fitting a fog lamp.
- Section No. N.26 Location and remedy of faults.
- Section No. N.27 Headlamp beam setting.
- Section No. N.28 Dry-charged batteries.
- Section No. N.29 Modified European light unit.
- Section No. N.30 Modified dynamo pulley and fan belt.
- Section No. N.31 Sealed beam light units.
- Section No. N.32 Modified flashing direction indicators.

# WIRING DIAGRAM

Up to Chassis Nos. 2192 (Standard) and 2291 (Coupe)

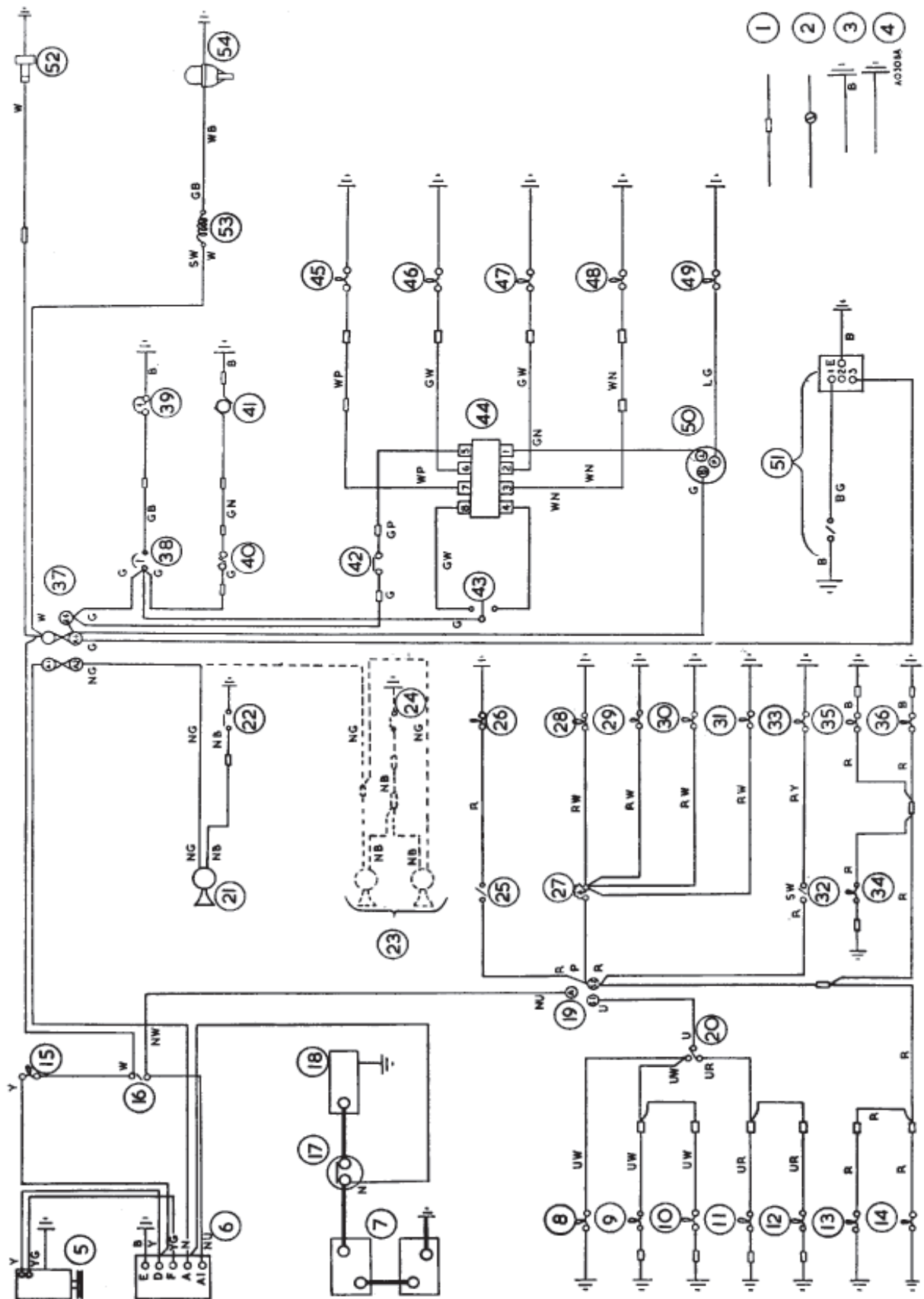

## KEY TO WIRING DIAGRAM (R.H.D. AND L.H.D.)

- |   |   |
|---|---|
| <p>1. Snap connectors.</p> <p>2. Terminal blocks or junction box.</p> <p>3. Earth connections made via cable.</p> <p>4. Earth connections made via fixing bolt.</p> <p>5. Generator.</p> <p>6. Control box.</p> <p>7. Two 6-volt batteries.</p> <p>8. Main beam warning light.</p> <p>9. R/H headlamp main beam.</p> <p>10. L/H headlamp main beam.</p> <p>11. R/H headlamp dip beam.</p> <p>12. L/H headlamp dip beam.</p> <p>13. L/H sidelamp.</p> <p>14. R/H sidelamp.</p> <p>15. Ignition warning light.</p> <p>16. Ignition switch.</p> <p>17. Starter switch.</p> <p>18. Starter motor.</p> | <p>19. Lighting switch.</p> <p>20. Dipper switch.</p> <p>21. Single horn (standard).</p> <p>22. Horn-push.</p> <p>23. Twin horns (optional extra).</p> <p>24. Horn-push.</p> <p>25. Map lamp switch.</p> <p>26. Map lamp.</p> <p>27. Panel light rheostat.</p> <p>28. Panel light.</p> <p>29. Panel light.</p> <p>30. Panel light.</p> <p>31. Panel light.</p> <p>32. Fog lamp switch.</p> <p>33. Fog lamp.</p> <p>34. L/H tail lamp.</p> <p>35. R/H tail lamp.</p> <p>36. Number-plate lamp.</p> |
| <p>37. Fuse block.</p> <p>38. Fuel gauge.</p> <p>39. Fuel tank unit.</p> <p>40. Heater switch.</p> <p>41. Heater motor.</p> <p>42. Stop lamp switch.</p> <p>43. Flasher switch.</p> <p>44. Relay.</p> <p>45. L/H rear flasher and stop lamp.</p> <p>46. L/H front flasher.</p> <p>47. R/H front flasher.</p> <p>48. R/H rear flasher and stop lamp.</p> <p>49. Flasher warning light.</p> <p>50. Flasher unit.</p> <p>51. Screen wiper switch and motor.</p> <p>52. Fuel pump.</p> <p>53. Ignition coil.</p> <p>54. Distributor.</p>  |   |

### CABLE COLOUR CODE

B Black	P Purple	Y Yellow
U Blue	R Red	D Dark
N Brown	S Slate	L Light
G Green	W White	M Medium
K Pink		

When a cable has two colour code letters the first denotes the main colour and the second denotes the tracer colour

## GENERAL DESCRIPTION

The 12-volt electrical equipment incorporates compensated voltage control for the charging circuit. The positive earth system of wiring is employed.

The two 6-volt batteries, mounted to the rear of the seats, are accessible for examination and maintenance attention.

The dynamo is mounted on the right of the cylinder block and driven by endless belt from the engine crankshaft. A rotatable mounting enables the belt tension to be adjusted.

The control box is sealed and should not normally need attention. The fuses and spare fuses are carried in external holders.

The starter motor is mounted on the flywheel housing on the right-hand side of the engine unit and operates on the flywheel through the usual sliding pinion device.

The headlamps employ the double-filament dipping system. Both lamps dip according to the regulations existing in the country concerned.

## Section N.1

## BATTERY MAINTENANCE

In order to keep the batteries in good condition a periodical inspection must be made.

Unscrew the five quick-release fasteners securing the panel immediately behind the seats and lift the panel away to obtain access to the batteries.

## Topping up

Remove the filler plug from each cell and examine the level of the electrolyte. Add distilled water as required to bring the level of the electrolyte just above the separators.

**NOTE.—Do not use tap-water and do not use a naked light when examining the condition of the cells. Wipe away all dirt and moisture from the top of the battery.**

## Testing the condition of the battery

Every 1,000 miles (1600 km.) examine the condition of the batteries by taking hydrometer readings. The hydrometer contains a graduated float on which is indicated the specific gravity of the acid in the cell from which the same is taken.

The specific gravity readings and their indications are as follows.

*Climates below 90° F. (32° C.)*

1·270 to 1·290	Cell fully charged.
1·190 to 1·210	Cell about half-discharged.
1·110 to 1·130	Cell fully discharged.

*Climates frequently above 90° F. (32° C.)*

1·210 to 1·230	Cell fully charged.
1·130 to 1·150	Cell about half-discharged.
1·050 to 1·070	Cell fully discharged.

**These figures are given assuming an electrolyte temperature of 60° F. (16° C.).** If the temperature of the electrolyte exceeds this, ·002 must be added to hydrometer readings for each 5° F. rise to give the true specific gravity. Similarly ·002 must be subtracted from hydrometer readings for every 5° F. below 60° F.

The readings of all the cells should be approximately the same. If one cell gives a reading very different from the rest it may be that the electrolyte has been spilled or has leaked from the cell or there may be an internal fault. Should a battery be in a low state of charge, it should be recharged by taking the car for a long daytime run or by charging from an external source of D.C. supply at a current rate of 5 amps. until the cells are gassing freely.

After examining the battery check the vent plugs, making sure that the air passages are clear.

## Storage

If a battery is to be out of use for any length of time it should first be fully charged and then given a freshening charge about every fortnight.

A battery must never remain in a discharged condition, as the plates will become sulphated.

## Initial filling and charging

When a new battery has been supplied dry it is necessary to fill the cells with electrolyte of the correct specific gravity.

Batteries having type suffix letter 'W' (e.g. SGW, etc.) are assembled with wet wood separators which have a diluting effect on the filling-in solution. To compensate for this dilution an acid having a higher specific gravity than that of a fully charged battery is required.

<i>Climate</i>	<i>S.G. of filling acid (correct to 60° F. [16° C.])</i>	<i>S.G. at end of charge</i>
Below 90° F. (32° C.)	.. 1·340	1·270 to 1·290
Over 90° F. (32° C.)	.. 1·290	1·210 to 1·230

All other batteries, including those having type suffix letter 'Z' (e.g. STGZ, etc.) and those having no additional suffix letter (e.g. SG, BT, etc.), are assembled with dry separators. The specific gravity of the filling-in solution for these batteries should be the same as that required at the end of the charge (i.e. 1·270 for climates below 90° F. [32° C.] and 1·210 for climates frequently above 90° F. [32° C.]). For more details of the requirements of 'dry-charged' batteries see Section N.28.

The electrolyte is prepared by mixing distilled water and concentrated sulphuric acid 1.835 S.G. The mixing must be carried out in a lead-lined tank or a suitable glass or earthenware vessel. Steel or iron containers must **not** be used. The acid must be added slowly to the water while the mixture is stirred with a glass rod. **Never add the water to the acid**, as the severity of the resulting chemical reaction may have dangerous consequences.

Heat is produced by the mixture of acid and water, and it should therefore be allowed to cool before it is poured into the battery, otherwise the plates, separators, and moulded container may be damaged.

The temperature of the filling-in acid, battery, and charging room should be above 32° F. (0° C.).

To produce electrolyte of the correct specific gravity:

<i>To obtain specific gravity</i>	<i>Add 1 part by volume of</i>
<i>(corrected to 60° F. [16° C.])</i>	<i>1.835 S.G. acid to distilled</i>
	<i>water by volume as below</i>
1.340	2.0 parts
1.290	2.7 parts
1.270	2.8 parts
1.210	4.0 parts

Carefully break the seals in the filling holes and half-fill each cell in the battery with dilute sulphuric acid solution of the appropriate specific gravity (according to temperature). The quantity of electrolyte required to half-fill a two-volt cell is  $\frac{1}{2}$  pint (.28 litre). Allow to stand for at least six hours, then complete the filling of the cells by the addition of more diluted acid of the same specific gravity as before until the level reaches the bottom of the filling holes, and allow the battery to stand for at least another two hours before commencing the first charge.

Charge at a constant current of 3.5 amps. until the voltage and temperature-corrected specific gravity readings show no increase over five successive hourly readings. This period is dependent upon the length of time the battery has been stored since manufacture, and will be from 40 to 80 hours, but usually not more than 60.

Throughout the charge the acid must be kept level with the tops of the separators in each cell by the addition of electrolyte of the same specific gravity as the original filling-in acid.

If, during charge, the temperature of the acid in any cell of the battery reaches the maximum permissible temperature of 100° F. (38° C.) in climates ordinarily below 90° F. (32° C.) or 120° F. (49° C.) in climates frequently above 90° F. (32° C.), the charge must be interrupted and the battery temperature allowed to fall at least 10° F. (5.5° C.) before charging is resumed.

At the end of the first charge, i.e. when specific gravity and voltage measurements remain constant, carefully

check the specific gravity in each cell to ensure that it lies within the limits specified. If any cell requires adjustment the electrolyte above the plates must be siphoned off and replaced either with acid of the strength used for the original filling in, or distilled water, according to whether the specific gravity is too low or too high respectively. After such adjustment, the gassing charge should be continued for one or two hours to ensure adequate mixing of the electrolyte. Re-check, if necessary, repeating the procedure until the desired result is obtained.

## Section N.2

### DYNAMO

#### To test on vehicle when dynamo is not charging

- (1) Make sure that belt slip is not the cause of the trouble. It should be possible to deflect the belt approximately  $\frac{1}{2}$  in. (13 mm.) at the centre of its longest run between two pulleys with moderate hand pressure. If the belt is too slack, loosen the two dynamo suspension bolts and then the bolt of the slotted adjustment link. A gentle pull on the dynamo outwards will enable the correct tension to be applied to the belt and all three bolts should then be tightened firmly.
- (2) Check the dynamo and control box connections. The dynamo terminal 'D' should be connected to the control box terminal 'D' and the dynamo terminal 'F' connected to the control box terminal 'F'.
- (3) After switching off all lights and accessories disconnect the cables from the dynamo terminals marked 'D' and 'F' respectively.
- (4) Connect the two terminals with a length of wire.
- (5) Start the engine and set to run at idling speed.
- (6) Clip the negative lead of a moving-coil-type voltmeter, calibrated 0-20 volts, to one dynamo terminal and the other lead to a good earthing point on the dynamo yoke.
- (7) Gradually increase the engine speed, when the voltmeter reading should rise rapidly and without fluctuation. Do not allow the voltmeter reading to reach 20 volts. Do not race the engine in an attempt to increase the voltage. It is sufficient to run the dynamo up to a speed of 1,000 r.p.m.

If there is no reading, check the brush gear.

If the reading is low (approximately 1 volt), the field winding may be faulty.

If the reading is approximately 5 volts, the armature winding may be faulty.

If the dynamo is in good order, leave the temporary link in position between the terminals and restore the original connections, taking care

to connect the dynamo terminal 'D' to the control box terminal 'D' and the dynamo terminal 'F' to the control box terminal 'F'. Remove the lead from the 'D' terminal on the control box and connect the voltmeter between this cable and a good earthing point on the vehicle. Run the engine as before. The reading should be the same as that measured directly at the dynamo. No reading on the voltmeter indicates a break in the cable to the dynamo. Carry out the same procedure for the 'F' terminal, connecting the voltmeter between cable and earth. Finally, remove the link from the dynamo. If the reading is correct test the control box (Section N.9).

**Section N.3**

**REMOVING AND REPLACING THE DYNAMO**

To remove the dynamo, disconnect the dynamo leads from the dynamo terminals.

Slacken all four attachment bolts and pivot the dynamo towards the cylinder block to enable the fan belt to be removed from the dynamo pulley. The dynamo can then be removed by completely removing the two upper and one lower attachment bolts.

Replacement of the dynamo is an exact reversal of this procedure.

**Section N.4**

**DISMANTLING THE DYNAMO**

Remove the securing nut and take off the drive pulley. Remove the Woodruff key from the commutator shaft.

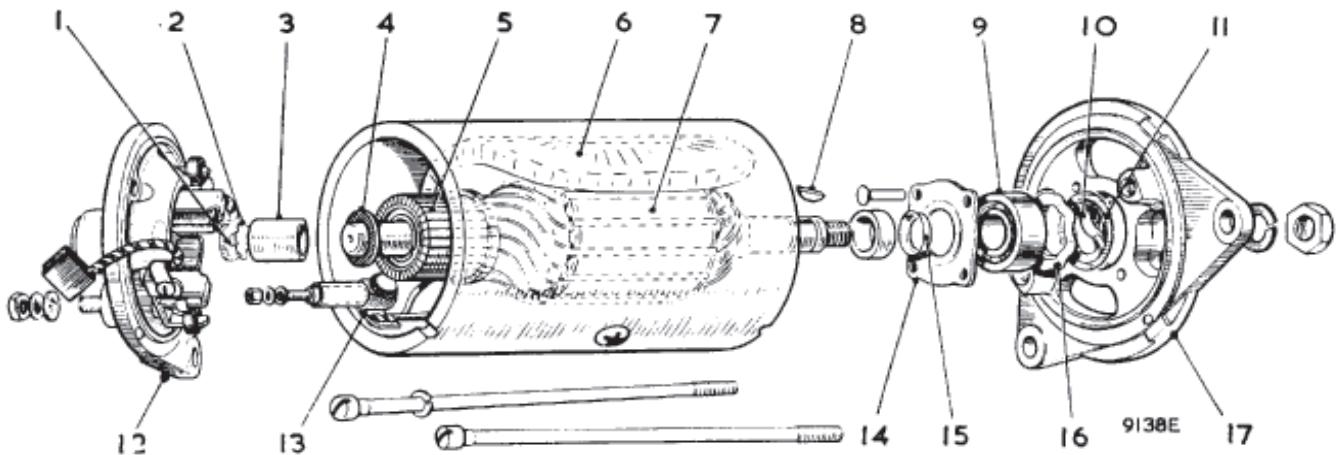

Fig. N.1

The windowless yoke dynamo

- |                    |                             |                              |
|--------------------|-----------------------------|------------------------------|
| 1. Felt pad.       | 7. Armature.                | 13. Field terminal post.     |
| 2. Aluminium disc. | 8. Shaft key.               | 14. Bearing retaining plate. |
| 3. Bronze bush.    | 9. Bearing.                 | 15. Cup washer.              |
| 4. Fibre washer.   | 10. Felt washer.            | 16. Corrugated washer.       |
| 5. Commutator.     | 11. Oil-retaining washer.   | 17. Driving end bracket.     |
| 6. Field coils.    | 12. Commutator end bracket. |                              |

Unscrew and remove the two through-bolts and take off the commutator end bracket. The driving end bracket, together with the armature and its ball bearing, can now be lifted out of the yoke. Unless the ball bearing is damaged or requires attention, it need not be removed from the armature. Should it be necessary to remove the bearing, the armature must be separated from the end bracket by means of a hand press.

Reassembly of the dynamo is a reversal of the dismantling procedure, except that when assembling the commutator end bracket the brushes must first be held clear of the commutator by partially withdrawing them from their boxes until each brush is trapped in position by the side pressure of its spring. The brushes can be released onto the commutator by a small screwdriver or similar tool when the end bracket is assembled to within about 1/8 in. (12.7 mm.) of the yoke. Before closing the gap between the end bracket and the yoke see that the springs are in correct contact with the brushes.

**Section N.5**

**SERVICING THE DYNAMO**

**Brushes**

Test if the brushes are sticking. Clean them with petrol and, if necessary, ease the sides by lightly polishing with a smooth file. Replace the brushes in their original positions.

Test the brush spring tension with a spring scale if available. The correct tension is 20 to 25 oz. (567 to 709 gm.). Fit a new spring if the tension is low.

If the brushes are worn so that the flexible lead is exposed on the running face new brushes **must** be fitted. Brushes are preformed so that bedding to the commutator is unnecessary.

### Commutator

A commutator in good condition will be smooth and free from pits or burned spots. Clean the commutator with a petrol-moistened cloth. If this is ineffective carefully polish with a strip of fine glass-paper while rotating the armature. To remedy a badly worn commutator, mount the armature (with or without the drive end bracket) in a lathe, rotate at high speed, and take a light cut with a very sharp tool. Do not remove more metal than is necessary. Polish the commutator with very fine glass-paper. Undercut the mica insulation between the segments to a depth of  $\frac{1}{32}$  in. (.8 mm.) with a hacksaw blade ground down to the thickness of the mica.

### Field coils

Test the field coils, without removing them from the dynamo yoke, by means of an ohmmeter. The reading on the ohmmeter should be between 6.0 and 6.3 ohms. If this is not available, connect a 12-volt D.C. supply with an ammeter in series between the field terminal and the dynamo yoke. The ammeter reading should be approximately 2 amps. If no reading is indicated the field coils are open-circuited and must be renewed. To test for earthed field coils, unsolder the end of the field winding from the earth terminal on the dynamo yoke and, with a test lamp connected from supply mains, test across the field terminal and earth. If the lamp lights, the field coils are earthed and must be renewed.

When fitting field coils, carry out the procedure outlined below, using an expander and wheel-operated screwdriver:

- (1) Remove the insulation piece which is provided to prevent the junction of the field coils from contacting the yoke.
- (2) Mark the yoke and pole-shoes in order that they can be refitted in their original positions.
- (3) Unscrew the two pole-shoe retaining screws by means of the wheel-operated screwdriver.
- (4) Draw the pole-shoes and coils out of the dynamo yoke and lift off the coils.
- (5) Fit the new field coils over the pole-shoes and place them in position inside the yoke. Take care to ensure that the taping of the field coils is not trapped between the pole-shoes and the yoke.



Fig. N.2

*The correct method of undercutting the dynamo commutator*

- (6) Locate the pole-shoes and field coils by lightly tightening the fixing screw.
- (7) Insert the pole-shoe expander, open it to the fullest extent, and tighten the screws.
- (8) Finally, tighten the screws by means of the wheel-operated screwdriver and lock them by caulking.
- (9) Replace the insulation piece between the field coil connections and the yoke.

### Armature

The testing of the armature winding requires the use of a voltage drop test and growler. If these are not available the armature should be checked by substitution. No attempt should be made to machine the armature core or to true a distorted armature shaft.

### Bearings

Bearings which are worn to such an extent that they will allow side-movement of the armature shaft must be replaced by new ones.

To fit a new bearing at the commutator end of the dynamo proceed as follows:

- (1) Press the bearing bush out of the commutator end bracket.
- (2) Press the new bearing bush into the end bracket, using a shouldered mandrel of the same diameter as the shaft which is to fit in the bearing.

**Before fitting the new bearing bush allow it to stand completely immersed in thin engine oil for 24 hours to fill the pores of the bush with lubricant.**

The ball bearing at the driving end is renewed as follows:

- (1) Knock out the rivets which secure the bearing retaining plate to the end bracket and remove the plate.
- (2) Press the bearing out of the end bracket and remove the corrugated washer, felt washer, and oil-retaining washer.
- (3) Before fitting the replacement bearing see that it is clean and pack it with a high-melting-point grease.
- (4) Place the oil-retaining washer, felt washer, and corrugated washer in the bearing housing in the end bracket.

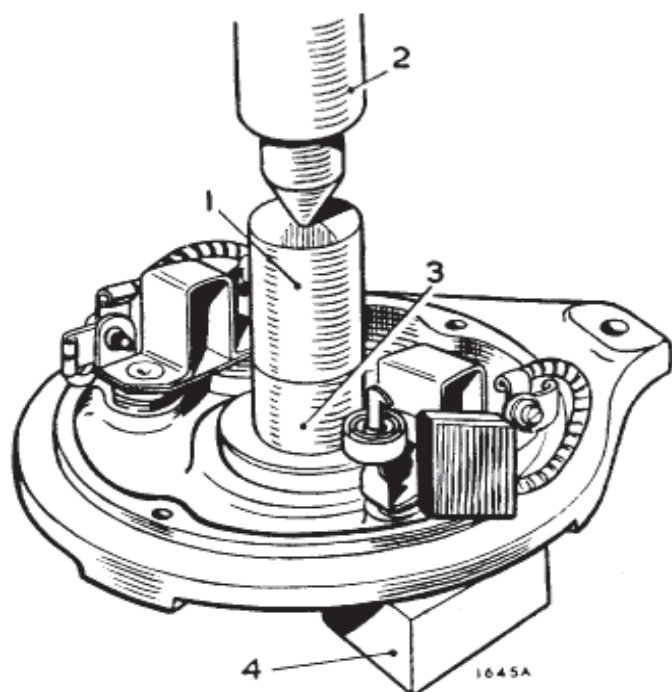

Fig. N.3

The method of pressing out the commutator end bracket bush is shown in this illustration

- |                        |                   |
|------------------------|-------------------|
| 1. Shouldered mandrel. | 3. Bearing bush.  |
| 2. Hand press.         | 4. Support block. |

- (5) Locate the bearing in the housing and press it home by means of a hand press.
- (6) Fit the bearing retaining plate. Insert the new rivets from the inside of the end bracket and open the rivets by means of a punch to secure the plate rigidly in position.

#### Reassembly

The reassembly of the dynamo is a reversal of the operations described in Section N.4.

If the end bracket has been removed from the armature in dismantling, press the bearing end bracket onto the armature shaft, taking care to avoid damaging the end plate and armature winding.

Add a few drops of oil through the hole in the armature end cover.

## Section N.6

### STARTER

#### To test on vehicle

Switch on the lamps and operate the starter control. If the lights go dim, but the starter is not heard to operate, an indication is given that current is flowing through the starter windings but that the starter pinion

is meshed permanently with the geared ring on the flywheel. This was probably caused by the starter being operated while the engine was still running. In this case the starter must be removed from the engine for examination.

Should the lamps retain their full brilliance when the starter switch is operated, check that the switch is functioning. If the switch is in order, examine the connections at the battery, starter switch, and starter, and also check the wiring between these units. Continued failure of the starter to operate indicates an internal fault, and the starter must be removed from the engine for examination.

Sluggish or slow action of the starter is usually caused by a poor connection in the wiring which produces a high resistance in the starter circuit. Check as described above.

Damage to the starter drive is indicated if the starter is heard to operate but does not crank the engine.

## Section N.7

### REMOVING AND REPLACING THE STARTER

Release the starter cable from the terminal and unscrew the two starter securing bolts. Manoeuvre the starter forwards below the oil filter, then rearwards and downwards.

## Section N.8

### SERVICING THE STARTER

#### Examination of commutator and brush gear

Remove the starter cover band (3) (Fig. N.4) and examine the brushes (8) (Fig. N.4) and the commutator. Hold back each of the brush springs (7) (Fig. N.4) and move the brush by pulling gently on its flexible connector. If the movement is sluggish remove the brush from its holder and ease the sides by lightly polishing with a smooth file. Always replace brushes in their original positions. If the brushes are worn so that they no longer bear on the commutator, or if the brush flexible lead has become exposed on the running face, they must be renewed.

If the commutator is blackened or dirty, clean it by holding a petrol-moistened cloth against it while the armature is rotated.

Secure the body of the starter in a vice and test by connecting it with heavy-gauge cables to a battery of the correct voltage. One cable must be connected to the starter terminal and the other held against the starter body or end bracket. Under these light load conditions the starter should run at a very high speed.



If the operation of the starter is still unsatisfactory, the starter should be dismantled for detailed inspection and testing.

### Dismantling

Take off the cover band (3) (Fig. N.4) at the commutator end, hold back the brush springs (7) (Fig. N.4), and take out the brushes (8) (Fig. N.4) from their holders.

Withdraw the jump ring and shims from the armature shaft at the commutator end and remove the armature complete with drive from the commutator end bracket and starter frame.

Remove the terminal nuts and washers (1) from the terminal post (4) at the commutator end bracket and also withdraw the two through-bolts. Remove the commutator end bracket and the attachment bracket from the starter frame.

### Brushes

- (1) Test the brush springs with a spring scale. The correct tension is 30 to 40 oz. (850 to 1134 gm.). Fit a new spring if the tension is low.
- (2) If the brushes are worn so that they no longer bear on the commutator, or if the flexible connector has become exposed on the running face, they must be renewed. Two of the brushes are con-

nected to terminal eyelets attached to the brush boxes on the commutator end bracket. The other two brushes are connected to tapings on the field coils.

The flexible connectors must be removed by unsoldering and the connectors of the new brushes secured in place by soldering. The brushes are preformed, so that bedding of the working face to the commutator is unnecessary.

### Drive

If the pinion is tight on the sleeve, wash in paraffin; renew any worn or damaged parts.

To dismantle the drive extract the split pin and remove the shaft nut (14) (Fig. N.4); withdraw the main spring and collar.

Rotate the barrel to push out the sleeve; remove the barrel and pinion.

The barrel and pinion are supplied as an assembly but the parts may be separated by extracting the retaining ring (12).

**NOTE.**—Should either the control nut or screwed sleeve be damaged, a replacement assembly, consisting of a screwed sleeve and control nut, must be fitted. These components must not be fitted individually.

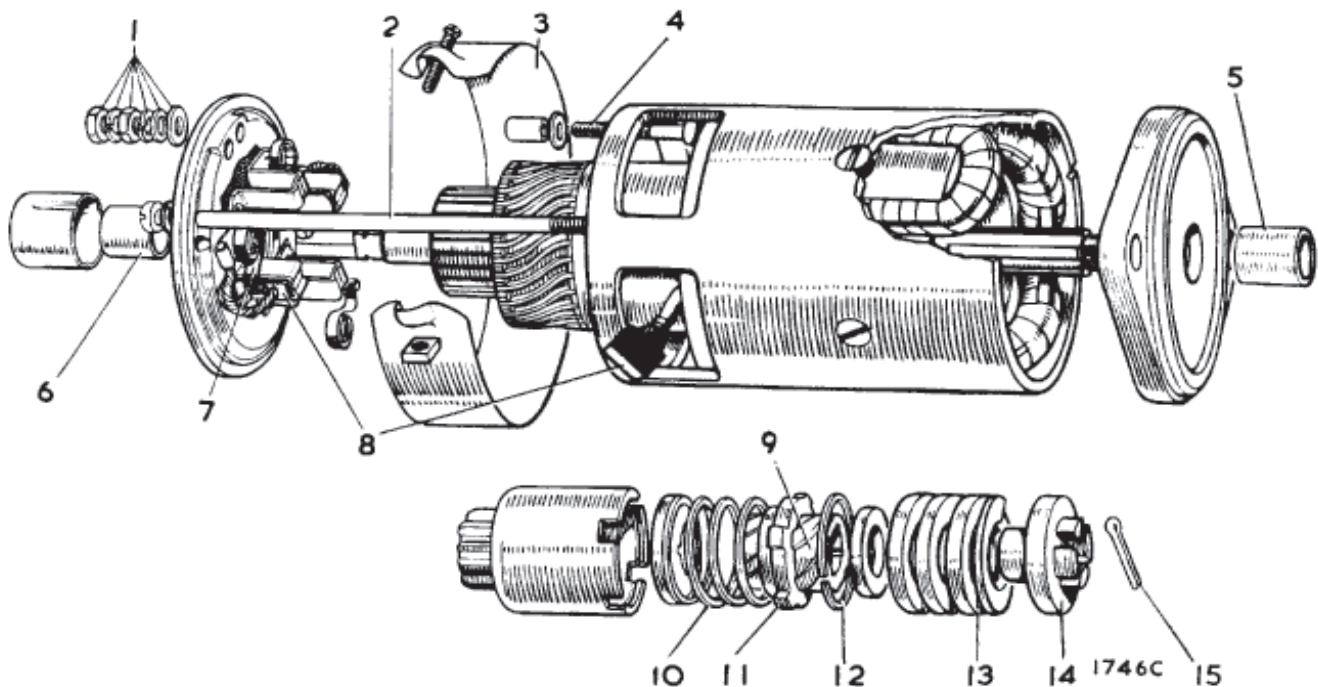

Fig. N.4

*An exploded view of the starter and drive*

- |                               |                         |                     |
|-------------------------------|-------------------------|---------------------|
| 1. Terminal nuts and washers. | 6. Bearing bush.        | 11. Control nut.    |
| 2. Through-bolt.              | 7. Brush spring.        | 12. Retaining ring. |
| 3. Cover band.                | 8. Brushes.             | 13. Main spring.    |
| 4. Terminal post.             | 9. Sleeve.              | 14. Shaft nut.      |
| 5. Bearing bush.              | 10. Restraining spring. | 15. Split pin.      |

**Commutator**

A commutator in good condition will be smooth and free from pits and burned spots. Clean the commutator with a cloth moistened with petrol. If this is ineffective, carefully polish with a strip of fine glass-paper while rotating the armature. To remedy a badly worn commutator dismantle the starter drive as described above and remove the armature from the end bracket. Now mount the armature in a lathe, rotate it at a high speed, and take a light cut with a very sharp tool. Do not remove any more metal than is absolutely necessary, and finally polish with very fine glass-paper.

The mica on the starter commutator **must not be undercut**.

**Field coils**

The field coils can be tested for an open circuit by connecting a 12-volt battery, having a 12-volt bulb in one of the leads, to the tapping point of the field coils to which the brushes are connected and the field terminal post. If the lamp does not light there is an open circuit in the wiring of the field coils.

Lighting of the lamp does not necessarily mean that the field coils are in order, as it is possible that one of them may be earthed to a pole-shoe or to the yoke. This may be checked by removing the lead from the brush connector and holding it on a clean part of the starter yoke. Should the bulb now light, it indicates that the field coils are earthed.

Should the above tests indicate that the fault lies in the field coils, they must be renewed. When renewing field coils carry out the procedure detailed for the dynamo (Section N.5).

**Armature**

Examination of the armature will in many cases reveal the cause of failure, e.g. conductors lifted from the commutator due to the starter being engaged while the engine is running and causing the armature to be rotated at an excessive speed. A damaged armature must in all cases be renewed—no attempt should be made to machine the armature core or to true a distorted armature shaft.

**Bearings (commutator end)**

Bearings which are worn to such an extent that they will allow excessive side-play of the armature shaft must be renewed. To renew the bearing bush, proceed as follows: press the new bearing bush into the end bracket, using a shouldered mandrel of the same diameter as the shaft which is to fit in the bearing.

The bearing bush is of the porous phosphor-bronze type, and before fitting, **new bushes should be allowed to stand completely immersed for 24 hours in thin engine oil in order to fill the pores of the bush with lubricant**.

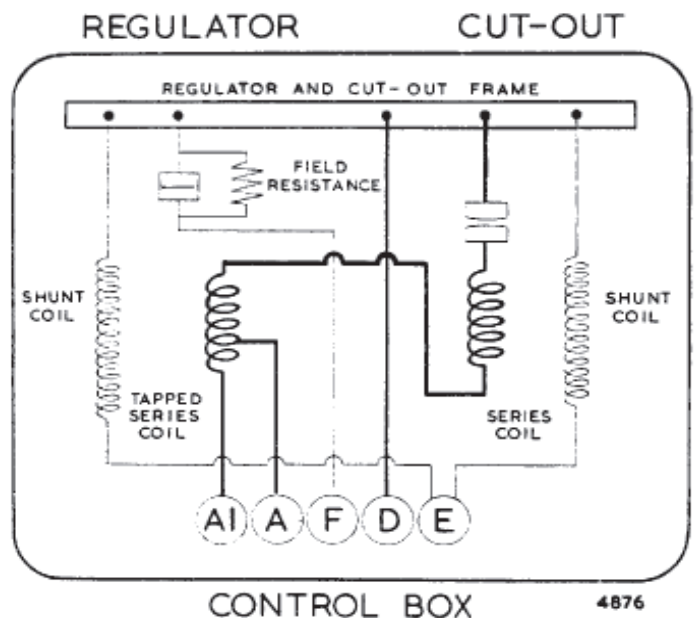

Fig. N.5

*The internal wiring and connections of the regulator and cut-out*

**Reassembly**

The reassembly of the starter is a reversal of the operations described in this Section.

**Section N.9****CONTROL BOX****Description**

The control box contains two units—a voltage regulator and a cut-out. Although combined structurally, the regulator and cut-out are electrically separate (see Fig. N.5).

Both are accurately adjusted during manufacture, and the cover protecting them should not be removed unnecessarily.

Cable connections are secured by grub-screw-type terminals.

**Regulator**

The regulator is set to maintain the dynamo output between close limits at all speeds above the regulating point, the field strength being controlled by the automatic insertion and withdrawal of a resistance in the dynamo field circuit. When the dynamo output reaches a predetermined value the magnetic flux in the regulator core, induced by the shunt or voltage winding, becomes sufficiently strong to attract the armature to the core. This causes the contacts to open, thereby inserting the resistance in the dynamo field circuit.

The consequent reduction in the dynamo field current lowers the dynamo output, and this, in turn, weakens the magnetic flux in the regulator core. The armature therefore returns to its original position, and with the contacts closed the dynamo output rises again to its regulated maximum. This cycle is then repeated and an oscillation of the armature is maintained.

As the speed of the dynamo rises above that at which the regulator comes into operation, the periods of contact separation increase in length and, as a result, the mean value of the dynamo output undergoes practically no increase once this regulating speed has been attained.

The series or current winding provides a compensation on this system of control, for if the control were arranged entirely on the basis of voltage there would be a risk of seriously overloading the dynamo when the battery was in a low state of charge, particularly if the lamps were in use simultaneously.

Under these conditions, with a battery of low internal resistance, the dynamo output rises and, but for the series winding, would exceed its normal rating. The magnetism due to the series winding assists the shunt winding, so that when the dynamo is delivering a heavy current into a discharged battery the regulator comes into operation at a somewhat reduced voltage, thus limiting the output accordingly. As shown in Fig. N.5, a split series winding is used, terminal 'A' being connected to the battery and terminal 'A1' to the lighting and ignition switch.

By means of a temperature compensation device the voltage characteristic of the dynamo is caused to conform more closely to that of the battery under all climatic conditions. In cold weather the voltage required to charge the battery at a given rate increases, whilst in warm weather the voltage required is lower. The compensation device is in the form of a bi-metal spring located behind the tensioning spring of the regulator armature. By causing the operating voltage of the regulator to be increased in cold weather and reduced in hot weather the bi-metal spring compensates for the changing temperature characteristics of the battery and prevents undue variation of the charging current which would otherwise occur. The bi-metal spring also compensates for effects due to increases in resistance of the copper windings from cold to working values.

**Cut-out**

The cut-out is an electro-magnetically operated switch connected in the charging circuit between the dynamo and the battery. It automatically connects the dynamo with the battery when the dynamo output exceeds that of the battery and disconnects the two when the dynamo output falls below that of the battery, and so prevents

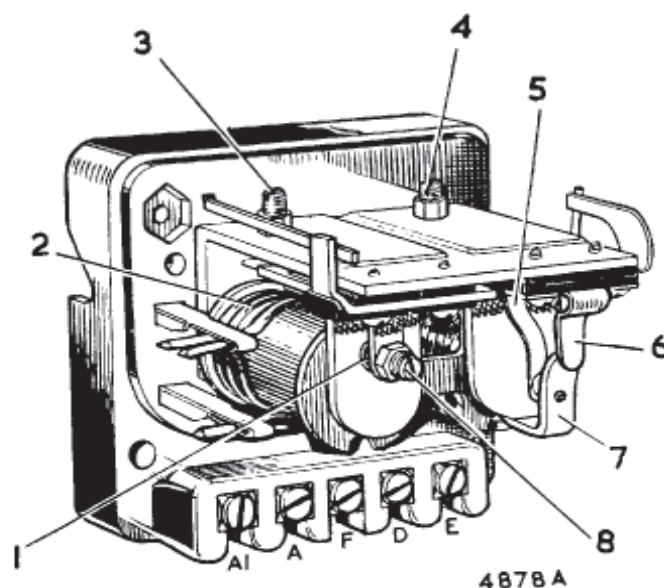

Fig. N.6

- 1. Regulator moving contact.
- 2. Regulator series windings.
- 3. Regulator adjusting screw.
- 4. Cut-out adjusting screw.
- 5. Fixed contact blade.
- 6. Stop arm.
- 7. Armature tongue and moving contact.
- 8. Regulator fixed contact screw.

the battery from discharging and possibly damaging the dynamo windings.

The cut-out consists of an electro-magnet fitted with an armature which operates a pair of contacts. The electro-magnet employs two windings—a shunt winding of many turns of fine wire and a series winding of a few turns of heavier-gauge wire. The contacts are normally held open and are closed only when the magnetic pull from the armature is sufficient to overcome the tension of the adjusting spring.

The shunt coil is connected across the dynamo. When starting, the speed of the engine and thus the output of the dynamo rises until the electro-magnet is strong enough to overcome the spring tension and close the cut-out contacts. The effect of the charging current flowing through the cut-out windings creates a magnetic field in the same direction as that produced by the shunt winding. This increases the magnetic pull on the armature so that the contacts are firmly closed and cannot be separated by vibration. When the speed of the dynamo falls to a point where its output is lower than that of the battery, current flows from the battery through the cut-out series winding and dynamo in a reverse direction to the charging current. This reverse current through the cut-out will produce a differential action between the two windings and partly demagnetize the electro-magnet. The spring, which is under constant tension, then pulls the armature away from the magnet and so separates the contacts and opens the circuit.

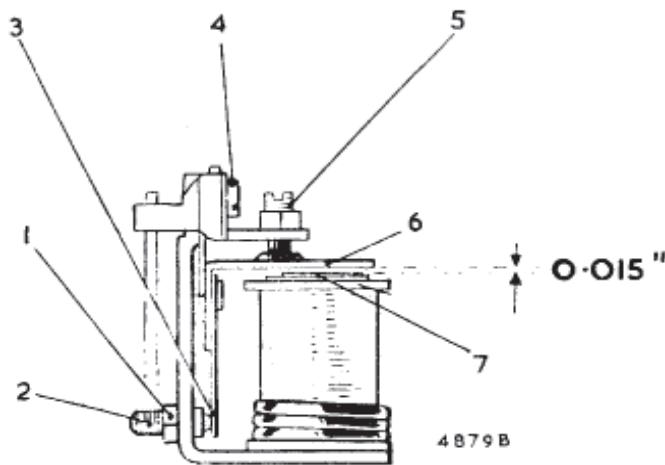

Fig. N.7

*Mechanical setting of the regulator*

- |                             |                                    |
|-----------------------------|------------------------------------|
| 1. Locknut.                 | 5. Fixed contact adjustment screw. |
| 2. Voltage adjusting screw. | 6. Armature.                       |
| 3. Armature tension spring. | 7. Core face and shim.             |
| 4. Armature securing screw. |                                    |

Like the regulator, the operation of the cut-out is temperature controlled by means of a bi-metal tensioning spring.

**Regulator adjustment**

The regulator is carefully set before leaving the Works to suit the normal requirements of the standard equipment, and in general it should not be necessary to alter it. If, however, the battery does not keep in a charged condition, or if the dynamo output does not fall when the battery is fully charged, it may be advisable to check the setting and, if necessary, to readjust it.

It is important, before altering the regulator setting, when the battery is in a low state of charge, to check that its condition is not due to a battery defect or to the dynamo belt slipping.

**Electrical setting (with unit cold)**

The electrical setting of the control unit can be checked without removing the cover. Use a good-quality moving-coil voltmeter (0-20 volts).

Withdraw the cables from the control box terminals 'A' and 'A1' and connect these cables together.

Connect the negative lead of the voltmeter to the control box terminal 'D' and connect the other lead to terminal 'E'.

Slowly increase the speed of the engine until the voltmeter needle 'flicks' and then steadies. This should occur at a voltmeter reading between the appropriate limits given in 'GENERAL DATA', according to the ambient temperature.

If the voltage at which the reading becomes steady occurs outside these limits the regulator must be adjusted.

Switch off the engine and remove the control box cover.

Slacken the voltage adjusting screw locknut (1), Fig. N.7) and turn the screw in a clockwise direction to raise the setting or in an anti-clockwise direction to lower the setting. Turn the screw only a fraction of a turn at a time and then tighten the locknut. Repeat as above until the correct setting is obtained.

The adjustment of the regulator open-circuit voltage should be completed within 30 seconds, otherwise heating of the shunt winding will cause false settings to be made.

A generator run at high speed on open circuit will build up a high voltage. Therefore, when adjusting the regulator, increase the engine speed slowly until the regulator operates, otherwise a false setting may be made.

Reconnect the wires.

**Mechanical setting**

The mechanical or air gap settings of the regulator shown in Fig. N.7 are accurately adjusted before leaving the Works and, provided that the armature carrying the moving contact is not removed, these settings must not be tampered with. If, however, the armature has been removed, the regulator will have to be reset. To do this proceed as follows.

Slacken the fixed contact locking nut and unscrew the contact screw until it is quite clear of the armature moving contact.

Slacken the voltage adjusting screw locking nut and unscrew the adjuster until it is well clear of the armature tension spring.

Slacken the two armature assembly securing screws.

Using a .015 in. (.381 mm.) thick feeler gauge, wide enough to cover completely the core face, insert the gauge between the armature and the core shim, taking care not to turn up or damage the edge of the shim.

Press the armature **squarely** down against the gauge and retighten the two armature assembly securing screws.

With the gauge still in position, screw the adjustable contact down until it just touches the armature contact. Retighten the locking nut.

Reset the voltage adjusting screw as described under 'Regulator adjustment'.

**Cleaning contacts**

After long periods of service it may be found necessary to clean the regulator contacts. Clean the contacts by means of a fine carborundum stone or fine emery-cloth.

Carefully wipe away all traces of dust or other foreign matter with methylated spirits.

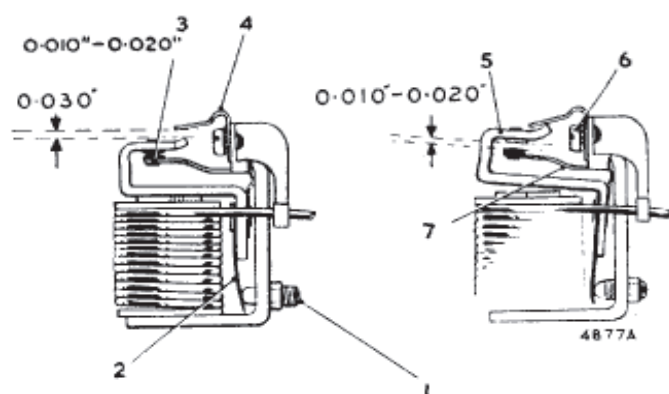

Fig. N.8

### Mechanical setting of the cut-out

- |   |  |
|---|--|
| 1. Cut-out adjusting screw.                         | 5. Armature tongue and moving contact. |
| 2. Armature tension spring.                         | 6. Armature securing screw.            |
| 3. 'Follow through'— $\cdot 010$ to $\cdot 020$ in. | 7. Fixed contact blade.                |
| 4. Stop arm.  |  |

### Cut-out adjustment

#### Electrical setting

If the regulator is correctly set but the battery is still not being charged, the cut-out may be out of adjustment. To check the voltage at which the cut-out operates remove the control box cover and connect the voltmeter between terminals 'D' and 'E'. Start the engine and slowly increase its speed until the cut-out contacts are seen to close, noting the voltage at which this occurs. It should be 12.7 to 13.3 volts.

If the cut-out operates outside these limits it will be necessary to adjust it to within the limits. To do this slacken the locknut securing the cut-out adjusting screw (1) (Fig. N.8) and turn the screw in a clockwise direction to raise the voltage setting or in an anti-clockwise direction to reduce the setting. Turn the screw only a fraction of a turn at a time and then tighten the locknut. Test after each adjustment by increasing the engine speed and noting the voltmeter readings at the instant of contact closure. Electrical settings of the cut-out, like the regulator, must be made as quickly as possible because of the temperature rise effects.

If the cut-out does not operate there may be an open circuit in the wiring of the cut-out and regulator unit, in which case the unit should be removed for examination or replacement.

#### Mechanical setting

If for any reason the cut-out armature has to be removed from the frame care must be taken to obtain the correct air-gap settings on reassembly. These can be obtained as follows.

Slacken the adjusting screw locknut and unscrew the cut-out adjusting screw until it is well clear of the armature tension spring.

Slacken the two armature securing screws.

Press the armature **squarely** down against the copper-sprayed core face and retighten the armature securing screws.

Using a pair of thin-nosed pliers, adjust the gap between the armature stop arm and the armature tongue by bending the stop arm. The gap must be  $\cdot 030$  in. ( $\cdot 762$  mm.) when the armature is pressed **squarely** down against the core face.

Similarly, the fixed contact blade must be bent so that when the armature is pressed **squarely** down against the core face there is a 'follow through' of blade deflection of  $\cdot 010$  to  $\cdot 020$  in. ( $\cdot 254$  to  $\cdot 508$  mm.). See (3) (Fig. N.8).

Reset the cut-out adjusting screw in accordance with the instructions already given.

### Cleaning contacts

Do not use emery-cloth or a carborundum stone for cleaning cut-out contacts. If the contacts appear dirty, rough, or burnt, place a strip of fine glass-paper between the contacts, and then, with the contacts closed by hand, draw the paper through. This should be done two or three times with the rough side of the glass-paper towards each contact.

Wipe away all dust or other foreign matter, using a clean, fluffless cloth moistened with methylated spirits.

## Section N.10

### FUSES

Two 35-amp. fuses are mounted in a separate fusebox and are therefore accessible without removing the control box cover.

#### Units protected

The units which are protected by each fuse can readily be identified by referring to the wiring diagram on page N.2.

#### Blown fuses

A blown fuse is indicated by the failure of all the units protected by it, and is confirmed by examination of the fuse, which can easily be withdrawn from the spring clips. If it has blown, the fused state of the wire will be visible inside the glass tube. Before renewing a blown fuse inspect the wiring of the units that have failed for evidence of a short circuit or other faults which may have caused the fuse to blow, and remedy the cause of the trouble.

## Section N.11

### ELECTRIC HORN

If the horn fails or becomes uncertain in its action it does not follow that the horn has broken down. First

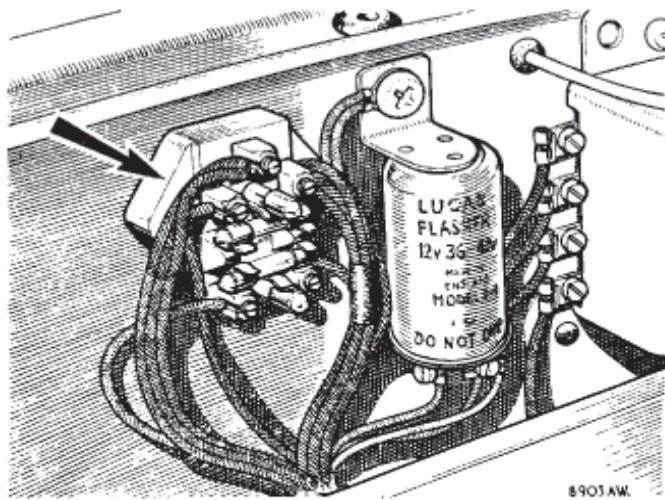

Fig. N.9

*The fuses and flasher unit*

ascertain that the trouble is not due to a loose or broken connection in the wiring of the horn. If the fuse has blown examine the wiring for the fault and replace with the spare fuse provided.

The performance of a horn may be upset by a loose fixing bolt, or by some component near the horn being loose. If after carrying out the above examination the trouble is not rectified, the horn may need adjustment.

Adjustment does not alter the pitch of the note: it merely takes up wear of moving parts. When adjusting the horn, short-circuit the fuse, otherwise it is liable to blow. Again, if the horn will not sound on adjustment release the push instantly.

#### Adjustment

Remove the fixing screw from the top of the horn and take off the cover. Detach the cover securing bracket by springing it out of its location.

Slacken the locknut on the fixed contact and rotate the adjusting nut until the contacts are just separated (indicated by the horn failing to sound). Turn the adjusting nut half a turn in the opposite direction and secure it in this position by tightening the locknut.

## Section N.12

### FLASHING DIRECTION INDICATORS

The flashing direction indicators are operated by a pneumatic time switch through a flasher unit and a relay to the dual-filament bulbs in the side and tail lamps. In the event of failure carry out the following procedure:

- (1) Check bulbs for broken filaments.
- (2) Refer to the wiring diagram and check over flasher circuit connections.

- (3) Switch on the ignition and check that terminal 'B' on the flasher is at 12 volts with respect to earth.
- (4) Connect together terminals 'B' and 'L' at the flasher unit and operate the direction indicator switch.

If the flasher lights now work, the flasher unit is defective and must be renewed.

If the lights do not work, the relay is defective and must be renewed.

The length of time the flasher is operating can be altered by screwing up the adjusting screw located in the small boss at the back of the time switch. Screw in to lengthen the time of operation and out to shorten the period.

## Section N.13

### WINDSHIELD WIPER

Normally the windshield wiper will not require any servicing apart from the occasional renewal of the rubber blades.

Should any trouble be experienced, first check for loose connections, worn insulation, etc., before dismantling the motor.

#### 1. To detach the cable rack from the motor and gearbox

Unscrew the pipe union nut.

Remove the gearbox cover.

Remove the split pin and washer from the crank-pin and final gear wheel.

Lift off the connecting link.

#### 2. Commutator dirty

Remove the connecting leads to the terminals, and withdraw the three screws securing the cover at the commutator end. Lift off the cover. Clean the commutator with a cloth moistened with petrol (gasoline) and carefully remove any carbon dust from between the commutator segments.

#### 3. Brush lever stiff or brushes not bearing on commutator

Check that the brushes bear freely on the commutator. If they are loose and do not make contact a replacement tension spring is necessary. The brush levers must be free on their pivots. If they are stiff they should be freed by working them backwards and forwards by hand and by applying a trace of thin machine oil. Packing shims are fitted beneath the legs of the brush to ensure that the brushes are central and that there is no possibility of the brush boxes fouling the commutator. If the brushes are considerably worn they must be replaced by new ones.

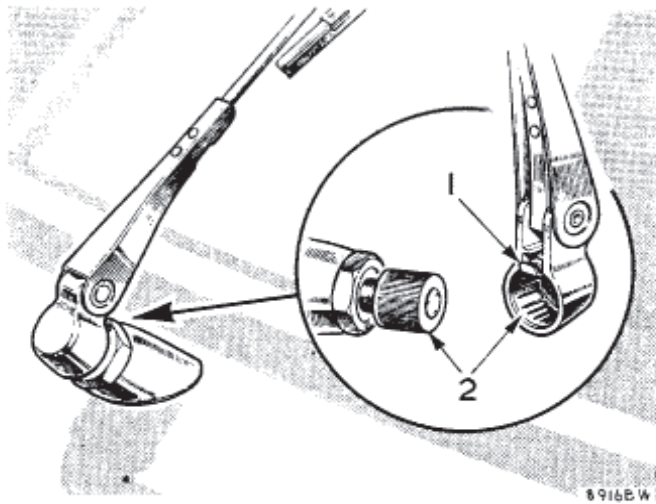

Fig. N.10

To reposition the wiper arm press the spring clip (1), withdraw the arm, and refit on another spline (2)

**4. Motor operates but does not transmit motion to spindles**

Remove the cover of the gearbox. A push-pull motion should be transmitted to the inner cable of the flexible rack. If the cross-head moves sluggishly between the guides lightly smear a small amount of medium-grade engine oil in the groove formed in the die-cast housing. When overhauling, the gear must be lubricated by lightly packing the gearbox with a grease to Ref. C (page P.7).

**5. Thrust screw adjustments**

The thrust screw is located on the top of the cross-head housing. To adjust, slacken the locknut, screw down the thrust screw until it contacts the armature, and then turn back a fraction of a turn. Hold the thrust screw with a screwdriver and tighten the locknut.

**6. To remove the motor**

Detach the cable rack from the motor and gearbox as detailed above. Disconnect the lead. Remove the two screws securing the mounting bracket to remove the motor.

**Section N.14**

**HEADLAMPS**

The headlamps are built into the wings and are fitted with double-filament bulbs. The design is such that the bulb is correctly positioned in relation to the reflector, and no focusing is required when a replacement bulb is fitted.

**Anti-dazzle device**

The double-filament bulbs are controlled by a foot-operated dipping switch deflecting both headlamp beams downwards to avoid dazzle.

Certain countries have lighting regulations to which the foregoing arrangements do not conform, and cars exported to such countries have suitably modified lighting equipment.

**Section N.15**

**LIGHT UNITS**

The light units consist of a lamp glass, reflector, and a back-shell. The light unit is located to the front wing by three spring-loaded attachment screws in a domed shield attached to the wing. The back of the lamp is therefore sealed to give complete protection.

A dust- and weather-excluding rubber is fitted in the recess of the rim of the light unit and a plated rim is fitted over this to complete the weather-sealing.

**Section N.16**

**REMOVING THE LIGHT UNITS**

To remove the light unit for bulb replacement unscrew the retaining screw at the bottom of the plated lamp rim and lift the rim away from the dust-excluding rubber.

Remove the dust-excluding rubber, which will reveal the three spring-loaded screws. Press the light unit inwards against the tension of the springs and turn it in an anti-clockwise direction until the heads of the

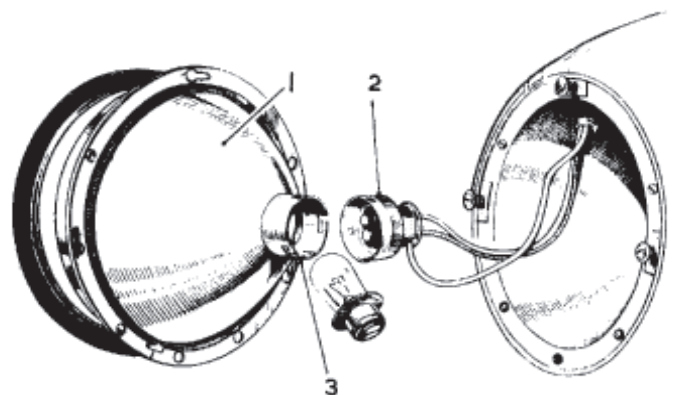

Fig. N.11

A light unit

- 1. Light unit.
- 2. Back-shell.
- 3. Bulb holder.

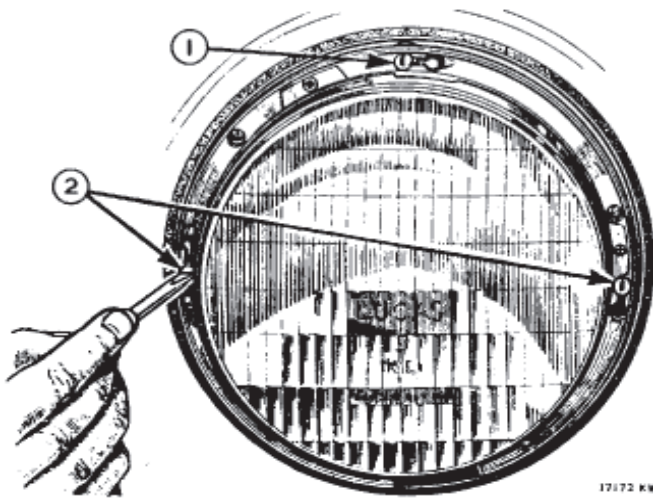

Fig. N.12

*The headlamp setting screws*

- |                                      |   |
|--------------------------------------|---|
| 1. Vertical setting adjusting screw. | 2. Horizontal setting adjusting screws. |
|--------------------------------------|---|

screws can pass through the enlarged ends of the keyhole slots in the lamp rim.

This will enable the light unit to be withdrawn sufficiently to give attention to the wiring and bulbs.

**Section N.17****SETTING THE HEADLAMPS**

The lamps should be set so that the main driving beams are parallel with the road surface (Section N.27) or in accordance with your local regulations.

If adjustment is required, this is achieved by removing the plated rim and dust-excluding rubber as indicated in Section N.16.

Vertical adjustment can then be made by turning the screws at the top of the lamp in the necessary direction.

Horizontal adjustment can be effected by using the adjustment screws on each side of the light unit (see Fig. N.12).

**Section N.18****REPLACING HEADLAMP BULBS**

Twist the back-shell anti-clockwise and pull it off. Withdraw the bulb from the holder.

Insert the replacement bulb in the holder, making sure that the slot in the periphery of the bulb flange engages the projection in the holder.

Engage the projections on the back-shell with the slots of the holder, press it on, and twist it clockwise until it engages with its catch.

**Section N.19****REPLACING THE LIGHT UNITS**

Position the light unit so that the heads of the adjusting screws coincide with the enlarged ends of the attachment slots. Push the light unit towards the wing to compress the springs and turn the unit to the right as far as it will go, that is, approximately  $\frac{1}{2}$  in. (13 mm.).

Replace the dust-excluding rubber on the light rim with its flanged face forward and refit the plated rim.

**Section N.20****TAIL LAMPS AND STOP LIGHTS**

The tail lamps are of the double-filament type, the second filament giving a marked increase in brilliance when the brakes are applied.

To obtain access to the bulbs remove the glass by withdrawing the two screws. The bulbs are held in bayonet-type holders with offset pins to ensure correct fitting.

**Section N.21****SIDELAMPS**

To obtain access to the bulb press the lamp front inwards and turn it anti-clockwise until it is free to be withdrawn. Reverse this movement to replace the front.

The locating pins on the bulb are offset to ensure that it is fitted correctly to give increased brilliance when the flashing equipment is operating.

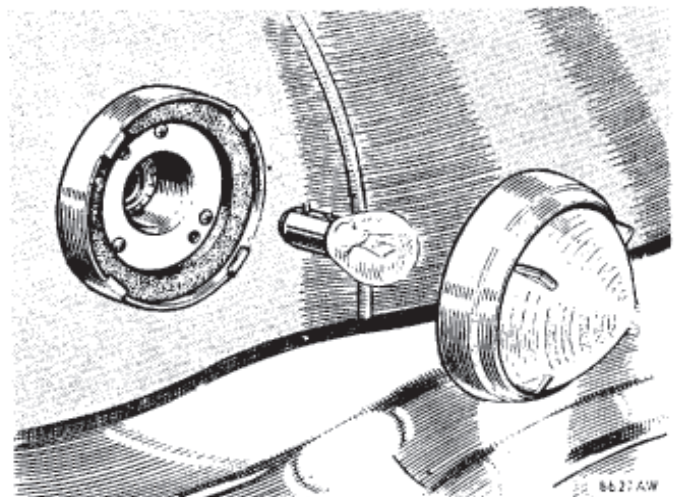

Fig. N.13

*Sidelamp bulb removal*



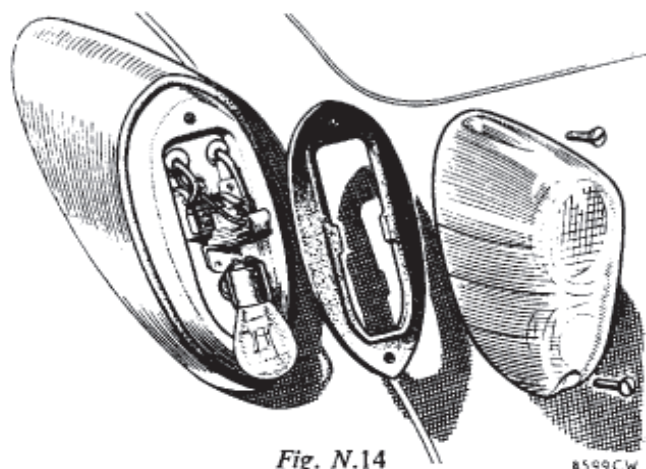

Fig. N.14

Removing a tail lamp bulb

**Section N.22**

**NUMBER-PLATE ILLUMINATION**

The number-plate is illuminated by a separate lamp and the domed cover is removed for bulb replacement by unscrewing the slotted screw and withdrawing the cover.

**Section N.23**

**PANEL AND WARNING LIGHTS**

The locations of the lamps illuminating the instruments and the warning lights are shown by arrows in Fig. N.15.

The bulbs are accessible from below the instrument panel.

**Section N.24**

**REPLACEMENT BULBS**

	B.M.C. Part No.	Watts	Volts
Headlamps (Home and Export R.H.D.—dip left) .. .. .	13H140 .. .. .	50/40	12
Headlamps (L.H.D.—not Europe—dip right) .. .. .	13H141 .. .. .	50/40	12
Headlamps (Europe except France—vertical dip) .. .. .	3H921 .. .. .	45/40	12
Headlamps (Europe except France—vertical dip) from Car No. 824 ..	13H138 .. .. .	45/40	12
Headlamps (France—vertical dip) from Car No. 1618 .. .. .	13H139 .. .. .	45/40	12
Headlamps (Sweden—vertical dip) from Car No. 2418 .. .. .	13H138 .. .. .	45/40	12
Sidelamps and stop/tail lamps .. .. .	1F9026 .. .. .	6/21	12
Number-plate illumination lamp .. .. .	2H4817 .. .. .	6	12
Panel lamps .. .. .	2H4732 .. .. .	2-2	12
Flashing indicator lamps .. .. .	1F9012 .. .. .	21	12

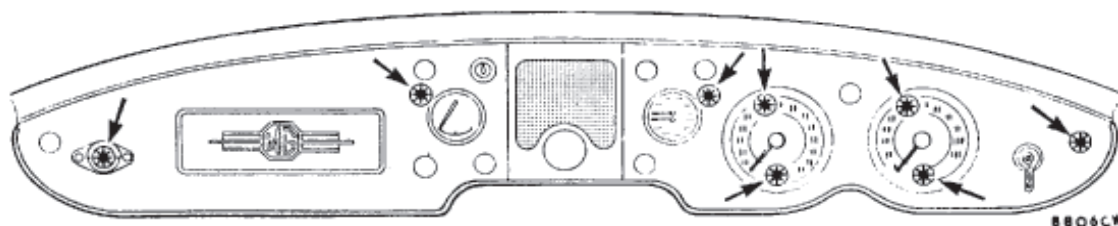

Fig. N.15

The panel and warning lights

**Section N.25**

**FITTING A FOG LAMP**

A fog lamp is not fitted as standard equipment, but can be supplied as an optional extra. The necessary wiring together with the switch (marked 'F' on the instrument panel) is already provided to accommodate the fitment.

To fit the fog lamp bracket remove the over-rider and place the bracket in position. Mark off and drill a further hole through the bumper to accommodate an additional  $\frac{1}{16}$  in. screw.

When mounted, the lamp is connected up to the spare red and yellow lead located behind the radiator grille to the right-hand side.

The necessary parts are shown below, together with their part numbers:

ADH785	Fog lamp .. .. .	2
AHH5454	Lead—fog lamp .. .. .	2
AHH5521	Bracket—R.H. .. .. .	1
AHH5520	Bracket—L.H. .. .. .	1
RG103	Grommet—lead .. .. .	4
HZS0506	Screw—bracket to blade (lower) .. .. .	2
FNZ105	Nut .. .. .	2
LWZ205	Spring washer .. .. .	2
PMP0518	Screw .. .. .	2
PMP105	Washer .. .. .	2

## Section N.26

## LOCATION AND REMEDY OF FAULTS

Although every precaution is taken to eliminate possible causes of trouble, failure may occasionally develop through lack of attention to the equipment, or damage to the wiring. The following pages set out the recommended procedure for a systematic examination to locate and remedy the causes of some of the more usual faults encountered.

The sources of trouble are by no means always obvious, and in some cases a considerable amount of deduction from the symptoms is needed before the cause is disclosed.

For instance, the engine might not respond to the starter switch; a hasty inference would be that the starter motor is at fault. However, as the motor is dependent on the batteries it may be that the batteries are exhausted.

This, in turn, may be due to the dynamo failing to charge the batteries, and the final cause of the trouble may be, perhaps, a loose connection in some part of the charging circuit.

If, after carrying out an examination, the cause of the trouble is not found, the equipment should be checked by the nearest Lucas Service Depot or Agent.

## CHARGING CIRCUIT

## 1. Batteries in low state of charge

- (a) This state will be shown by lack of power when starting, poor light from the lamps, and hydrometer readings below 1.200. It may be due to the dynamo not charging or giving low or intermittent output. The ignition warning light will not go out if the dynamo fails to charge, or will flicker on and off in the event of intermittent output.
- (b) Examine the charging and field circuit wiring, tightening any loose connections or renewing broken cables. Pay particular attention to the battery connections.
- (c) Examine the dynamo driving belt; take up any undue slackness by swinging the dynamo outwards on its mounting after slackening the attachment bolts.
- (d) Check the regulator setting, and adjust if necessary.
- (e) If, after carrying out the above, the trouble is still not cured, have the equipment examined by a Lucas Service Depot or Agent.

## 2. Batteries overcharged

This will be indicated by burnt-out bulbs, very frequent need for topping up the batteries, and high hydrometer

readings. Check the charge reading with an ammeter when the car is running. It should be of the order of only 3 to 4 amps.

If the ammeter reading is in excess of this value it is advisable to check the regulator setting, and adjust if necessary.

## STARTER MOTOR

## 1. Starter motor lacks power or fails to turn engine

- (a) See if the engine can be turned over by hand. If not, the cause of the stiffness in the engine must be located and remedied.
- (b) If the engine can be turned by hand, first check that the trouble is not due to a discharged battery.
- (c) Examine the connections to the batteries, starter, and starter switch, making sure that they are tight and that the cables connecting these units are not damaged.
- (d) It is also possible that the starter pinion may have jammed in mesh with the flywheel, although this is by no means a common occurrence. To disengage the pinion rotate the squared end of the starter shaft by means of a spanner.

## 2. Starter operates but does not crank the engine

This fault will occur if the pinion of the starter drive is not allowed to move along the screwed sleeve into engagement with the flywheel, due to dirt having collected on the screwed sleeve. Remove the starter and clean the sleeve carefully with paraffin (kerosene).

## 3. Starter pinion will not disengage from flywheel when engine is running

Stop the engine and see if the starter pinion is jammed in mesh with the flywheel, releasing it if necessary by rotation of the squared end of the starter shaft. If the pinion persists in sticking in mesh have the equipment examined at a Service Depot. Serious damage may result to the starter if it is driven by the flywheel.

## LIGHTING CIRCUITS

## 1. Lamps give insufficient illumination

- (a) Test the state of charge of the battery, recharging it if necessary from an independent electrical supply.
- (b) Check the setting of the lamps.
- (c) If the bulbs are discoloured as the result of long service they should be renewed.

2. Lamps light when switched on but gradually fade out  
As paragraph 1 (a).

## 3. Brilliance varies with speed of car

- (a) As paragraph 1 (a).
- (b) Examine the battery connections, making sure that they are tight, and renew any faulty cables.

**Section N.27**

**HEADLAMP BEAM SETTING**

Refer to Section N.17 for details of the headlamp adjustment screws.

In the absence of specialized proprietary equipment the setting of the lamps can be carried out by placing the loaded vehicle in front of a blank wall at a distance of 25 ft. (7.6 m.) or more, taking care that the surface on which the car is standing is level and not sloping in relation to the wall. It will be found an advantage to cover one lamp while setting the other.

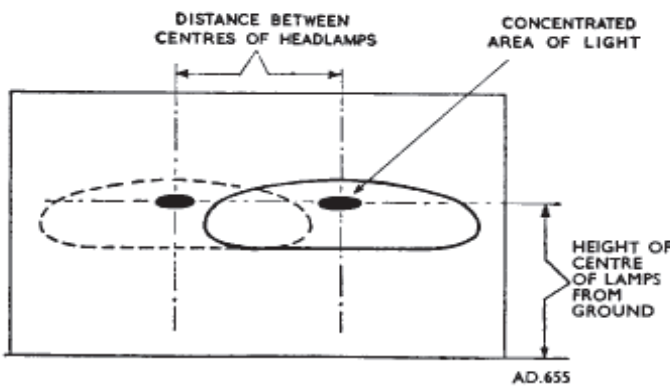

Fig. N.16  
Headlamp—alignment

**Section N.28**

**DRY-CHARGED BATTERIES**

'Dry-charged' batteries are supplied without electrolyte but with the plates in a charged condition. This ensures that there is no deterioration of the battery if it is stored for a period before use. These batteries have the type suffix letter 'Z' (e.g. STGZ, etc.).

Filling the cells with electrolyte of the correct specific gravity (see 'Initial filling and charging' of Section N.1), in one operation, renders the battery capable of giving a starting discharge one hour after filling. The temperature of the filling-in solution, battery, and filling room should be maintained between 60° F. (16° C.) and 100° F. (38° C.) If the battery has been stored in a cool place it should be allowed to warm up to room temperature before filling.

When time permits, a freshening charge at the normal recharge rate of the battery will ensure that the battery is fully charged. During the charge keep the electrolyte level with the top of the separators by the addition of distilled water. Check the electrolyte specific gravity at the end of the charge: if 1.270 acid was used to fill the

battery, the specific gravity should now be between 1.270 and 1.290: if 1.210 acid was used, the specific gravity should be between 1.210 and 1.230.

**Section N.29**

**MODIFIED EUROPEAN LIGHT UNIT**

Cars exported to Europe are now fitted with the new European-type headlamps. These lamp units are fitted with special bulbs and front lenses giving an asymmetrical beam to the right-hand or left-hand side according to the regulations prevailing in the country concerned. This modification was introduced on the following cars:

From Car No. 824 (Europe except France).

From Car No. 1618 (France).

From Car No. 2418 (Sweden).

Access to the bulb is gained in the same way as described in Section N.16. The bulb, however, is released from the reflector by withdrawing the three-pin socket and pinching the two ends of the wire retaining clip to clear the bulb flange (see Fig. N.17).

When replacing the bulb care must be taken to see that the rectangular pip on the bulb flange engages the slot in the reflector seating for the bulb.

Replace the spring clip with its coils resting in the base of the bulb flange and engaging in the two retaining lugs on the reflector seating.

The appropriate replacement bulbs are listed in Section N.24. They are not interchangeable with those used in conjunction with the Continental-type headlamps previously fitted.

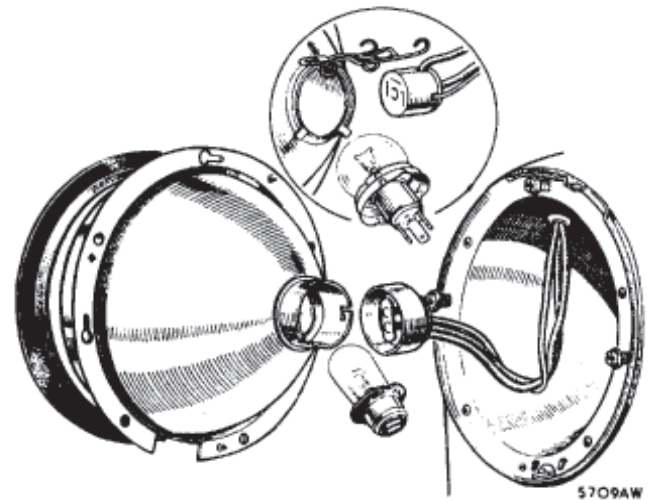
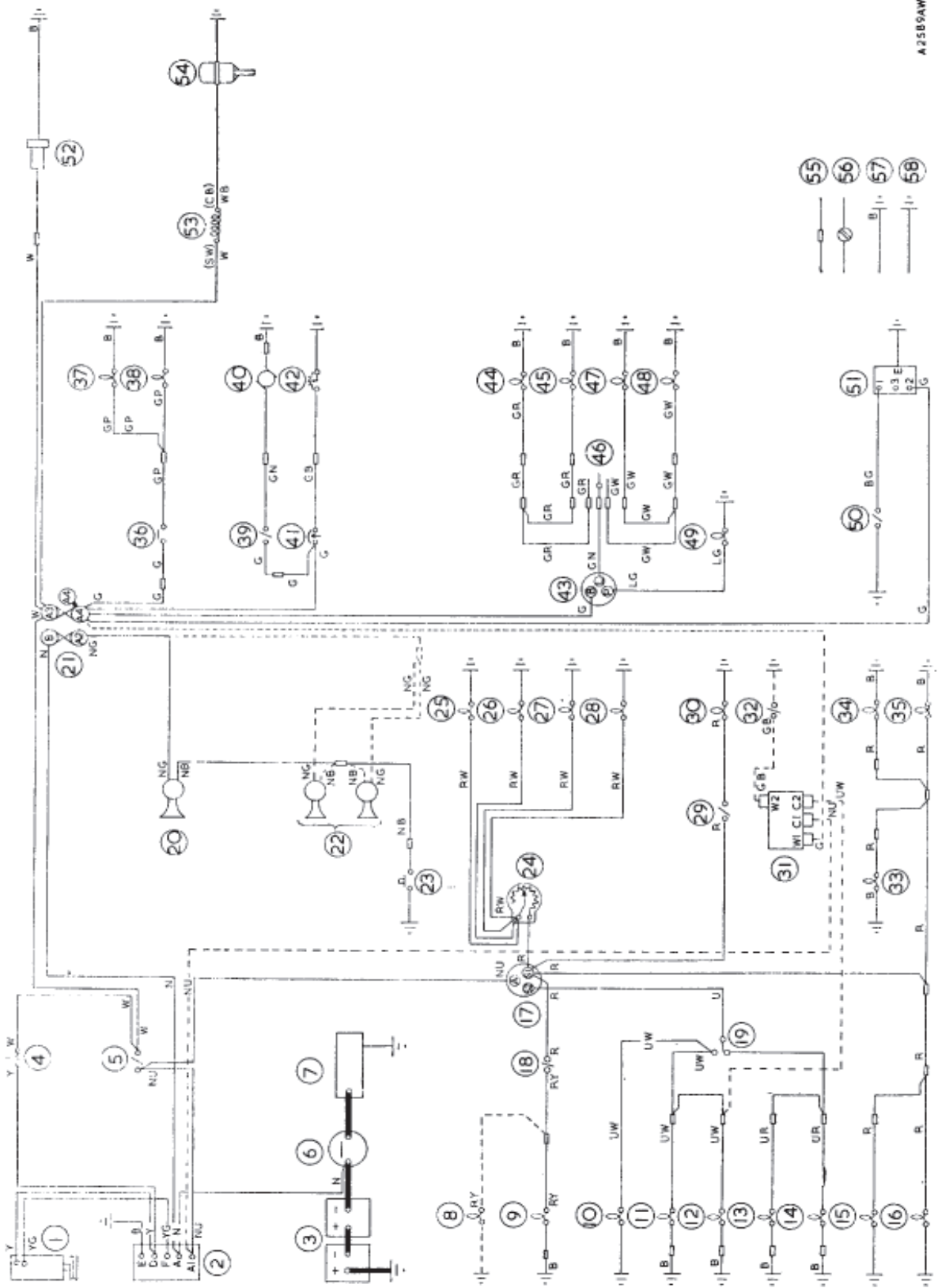

Fig. N.17  
The headlamp light unit, with the European-type lamp bulb arrangement inset

# WIRING DIAGRAM

From Chassis Nos. 2913 (Standard) and 2292 (Coupé).



A25B9AW

### KEY TO WIRING DIAGRAM (R.H.D. AND L.H.D.)

No.	Description	No.	Description	No.	Description
1.	Generator.	21.	Fuse unit.	41.	Fuel gauge.
2.	Control box.	22.	Twin windtone horns (if fitted).	42.	Fuel tank unit.
3.	Two 6-volt batteries.	23.	Horn push.	43.	Flasher unit.
4.	Ignition warning light.	24.	Panel lamp rheostat.	44.	L.H. rear flasher.
5.	Ignition switch.	25.	Panel lamp.	45.	L.H. front flasher.
6.	Starter switch.	26.	Panel lamp.	46.	Flasher switch.
7.	Starter motor.	27.	Panel lamp.	47.	R.H. front flasher.
8.	R.H. fog lamp (if fitted).	28.	Panel lamp.	48.	R.H. rear flasher.
9.	L.H. fog lamp.	29.	Map lamp switch.	49.	Flasher warning light.
10.	Main beam warning light.	30.	Map lamp.	50.	Windshield wiper switch.
11.	R.H. headlamp main beam.	31.	Headlamp flick relay.	51.	Windshield wiper motor.
12.	L.H. headlamp main beam.	32.	Headlamp flick switch.	52.	Fuel pump.
13.	L.H. headlamp dip beam.	33.	L.H. tail lamp.	53.	Ignition coil.
14.	R.H. headlamp dip beam.	34.	Number-plate lamp.	54.	Distributor.
15.	L.H. pilot lamp.	35.	R.H. tail lamp.	55.	Snap connectors.
16.	R.H. pilot lamp.	36.	Stop lamp switch.	56.	Terminal blocks or junction box.
17.	Lighting switch.	37.	L.H. stop lamp.	57.	Earth connections made via cable.
18.	Fog lamp switch.	38.	R.H. stop lamp.	58.	Earth connections made via fixing bolts.
19.	Dipper switch.	39.	Heater switch (when fitted).		
20.	Horn.	40.	Heater motor.		

CABLE COLOUR CODE

B. Black.	P. Purple.	Y. Yellow.
U. Blue.	R. Red.	L. Light.
N. Brown.	S. Slate.	D. Dark.
G. Green.	W. White.	M. Medium.

When a cable has two colour code letters, the first denotes the main colour and the second denotes the tracer colour.

## Section N.30

### MODIFIED DYNAMO PULLEY AND FAN BELT

To increase the dynamo charging rate at any given engine speed a smaller dynamo pulley (Part No. AEH605) and a shorter fan belt (Part No. AEH621) were introduced at Engine No. 272. This modification raises the dynamo pulley/crankshaft pulley speed ratio to 1.2 : 1.

The old and new dynamo pulleys and fan belts are interchangeable in sets.

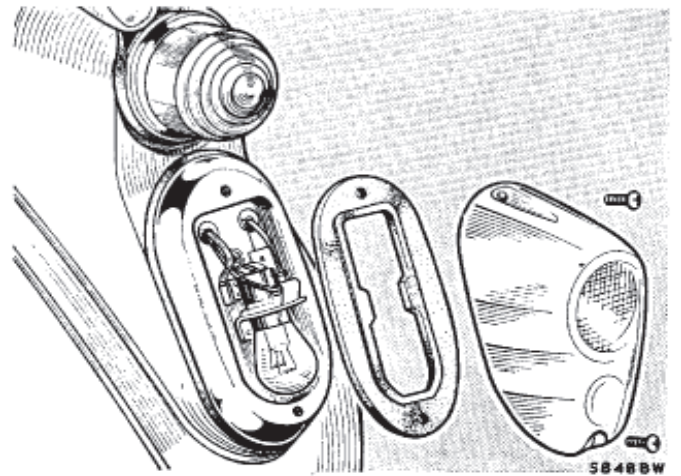

Fig. N.17

*Rear stop lamp and flasher lamp*

## Section N.31

### SEALED BEAM LIGHT UNITS

Cars exported to the U.S.A. are now fitted at the Works with headlamps incorporating sealed beam light units.

To change a sealed beam light unit, remove the headlamp rim and slacken the three retaining screws securing the light unit rim. Rotate the rim anti-clockwise to disengage the slotted holes from the heads of the retaining screws. Pull the light unit forward and disconnect the three-pin socket to release it from the back-shell.

## Section N.32

### MODIFIED FLASHING DIRECTION INDICATORS

Commencing at Chassis Nos. 2193 (Standard) and 2292 (Coupé), separate front and rear amber flashing direction indicators were introduced. The electrical relay is not used with this type of indicator.

To remove the flasher lamps, fold back the rubber flange surrounding the lamp rim and remove the rim and lens. The appropriate replacement bulbs are listed in Section N.24.