

MGA ENGINE MOUNT = RIGHT HAND
 Top Plate = 0.094 Mild Steel
 Bottom Plate = 0.075 Mild Steel
 Flex Mat'l = Vulcanized Rubber
 Studs = 5/16-24-UNF x 3/4 Pem Studs
 pressed or welded into top plate.
 Pin = ∅0.234 x 0.312 long mild steel
 pressed or welded into top plate.

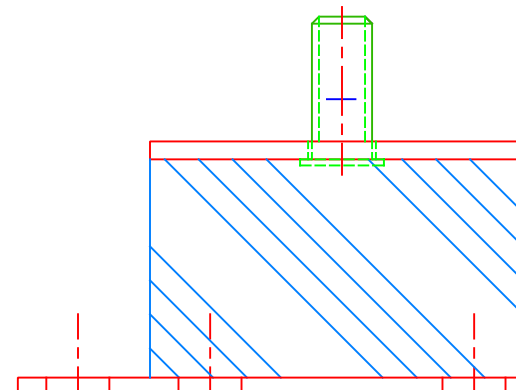

AHH5027